

Technical Data

Specifications & Capacities

RTC 80130

Series II

Telescopic Boom Rough Terrain Crane

130 US ton

120 metric ton

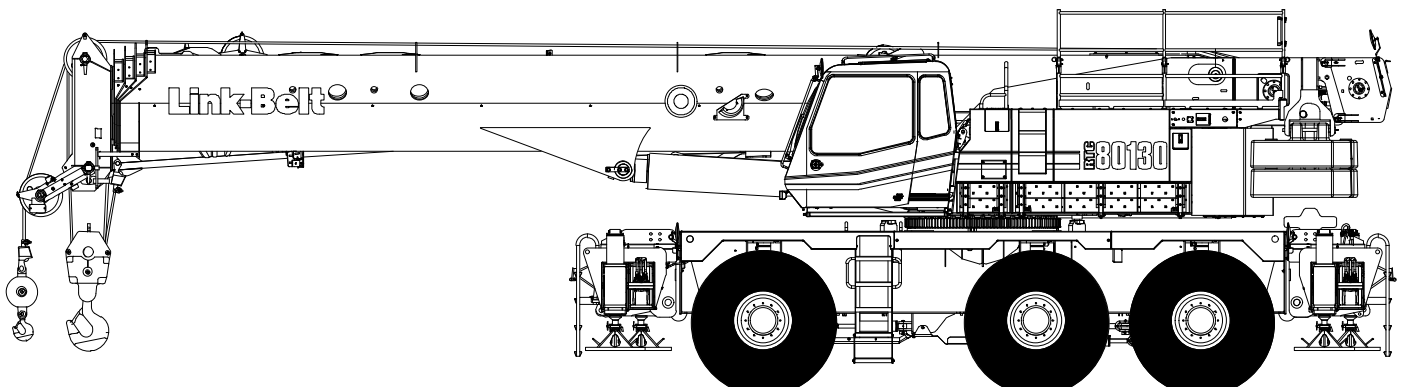

CAUTION: This material is supplied for reference use only. Operator must refer to in-cab Crane Rating Manual and Operator's Manual to determine allowable crane lifting capacities and assembly and operating procedures.

Table Of Contents

Boom, Attachments, and Upper Structure	1
Boom	1
Boom	1
Boom Wear Pads	1
Boom Head	1
Boom Elevation	1
Auxiliary Lifting Sheave — Optional	1
Hook Blocks and Balls — Optional	1
Fly — Optional	1
Fly Extensions — Optional	1
Operator's Cab and Controls	2
Swing	3
Electrical	3
Load Hoist System	4
Load Hoist Performance	4
2M Main (Front) and Optional Auxiliary (Rear) Winches	4
Engine	4
Drive System	5
Fuel Tank	5
Hydraulic System	5
Pump Drive	5
Counterweight	5
Carrier	7
General	7
Outriggers	7
Steering and Wheel Drive Motors	7
Suspension	7
Tires and Wheels	7
Brakes	7
Electrical	7
Hydraulic System	8
Maximum Speed	8
Gradeability	8
Paint	8
Axle Loads — Imperial	9
Axle Loads — Metric	10
Transport Configuration and Weights	11
General Dimensions	11
Working Range Diagram	12
Boom Extend Modes	13
Main Boom Lift Capacity Charts — Imperial	14
29,000 lb Counterweight — Fully Extended Outriggers — 360° Rotation	14
Main Boom Lift Capacity Charts — Optional	15
43,000 lb Counterweight — Fully Extended Outriggers — 360° Rotation	15
Manual Offset Fly Attachment Lift Capacity Charts — Optional	16
29,000 lb Counterweight — Fully Extended Outriggers — 360° Rotation	16
43,000 lb Counterweight — Fully Extended Outriggers — 360° Rotation	17

29,000 lb Counterweight — Fully Extended Outriggers — 360° Rotation	18
162 ft Main Boom Length	18
43,000 lb Counterweight — Fully Extended Outriggers — 360° Rotation	19
162 ft Main Boom Length	19
29,000 lb Counterweight — Fully Extended Outriggers — 360° Rotation	20
162 ft Main Boom Length	20
43,000 lb Counterweight — Fully Extended Outriggers — 360° Rotation	21
162 ft Main Boom Length	21
Hydraulic Offset Fly Attachment Lift Capacity Charts — Optional	22
29,000 lb Counterweight — Fully Extended Outriggers — 360° Rotation	22
Main Boom + 10 ft Hydraulic Offset Fly (2°–45° Offsets)	22
43,000 lb Counterweight — Fully Extended Outriggers — 360° Rotation	23
Main Boom + 10 ft Hydraulic Offset Fly (2°–45° Offsets)	23
29,000 lb Counterweight — Fully Extended Outriggers — 360° Rotation	24
162 ft Main Boom Length	24
43,000 lb Counterweight — Fully Extended Outriggers — 360° Rotation	25
162 ft Main Boom Length	25
29,000 lb Counterweight — Fully Extended Outriggers — 360° Rotation	26
162 ft Main Boom Length	26
43,000 lb Counterweight — Fully Extended Outriggers — 360° Rotation	27
162 ft Main Boom Length	27
On Tires Lift Capacity Charts — Imperial	28
26,000 lb Counterweight — On Tires — Stationary — Boom Centered Over Rear Between Tire Tracks	28
26,000 lb Counterweight — On Tires — Pick & Carry (Creep) — Boom Centered Over Rear	28
Metric Main Boom Lift Capacity Charts — 75% — Standard	29
13 154 kg Counterweight - Fully Extended Outriggers - 360° Rotation	29
Metric Main Boom Lift Capacity Charts — 75% — Optional	30
19 505 kg Counterweight - Fully Extended Outriggers - 360° Rotation	30
Metric Manual Offset Fly Attachment Lift Capacity Charts — 75% — Optional	31
13 154 kg Counterweight - Fully Extended Outriggers - 360° Rotation	31
19 505 kg Counterweight - Fully Extended Outriggers - 360° Rotation	32
13 154 kg Counterweight - Fully Extended Outriggers - 360° Rotation	33
19 505 kg Counterweight - Fully Extended Outriggers - 360° Rotation	33
13 154 kg Counterweight - Fully Extended Outriggers - 360° Rotation	34
19 505 kg Counterweight - Fully Extended Outriggers - 360° Rotation	34
Metric Hydraulic Offset Fly Attachment Lift Capacity Charts — 75% — Optional	35
13 154 kg Counterweight - Fully Extended Outriggers - 360° Rotation	35
19 505 kg Counterweight - Fully Extended Outriggers - 360° Rotation	36
13 154 kg Counterweight - Fully Extended Outriggers - 360° Rotation	37
19 505 kg Counterweight - Fully Extended Outriggers - 360° Rotation	37
13 154 kg Counterweight - Fully Extended Outriggers - 360° Rotation	38
19 505 kg Counterweight - Fully Extended Outriggers - 360° Rotation	38
Metric On Tires Lift Capacity Charts — 75% — Standard	39
11 794 kg Counterweight - On Tires - Stationary - Boom Centered Over Rear Between Tire Tracks ...	39
11 794 kg Counterweight - On Tires - Pick & Carry (Creep) - Boom Centered Over Rear	39
Metric Main Boom Lift Capacity Charts — 85% — Standard	40
13 154 kg Counterweight - Fully Extended Outriggers - 360° Rotation	40
Metric Main Boom Lift Capacity Charts — 85% — Optional	41
19 505 kg Counterweight - Fully Extended Outriggers - 360° Rotation	41

Metric Manual Offset Fly Attachment Lift Capacity Charts – 85% – Optional	42
13 154 kg Counterweight - Fully Extended Outriggers - 360° Rotation	42
19 505 kg Counterweight - Fully Extended Outriggers - 360° Rotation	43
13 154 kg Counterweight - Fully Extended Outriggers - 360° Rotation	44
19 505 kg Counterweight - Fully Extended Outriggers - 360° Rotation	44
13 154 kg Counterweight - Fully Extended Outriggers - 360° Rotation	45
19 505 kg Counterweight - Fully Extended Outriggers - 360° Rotation	45
Metric Hydraulic Offset Fly Attachment Lift Capacity Charts – 85% – Optional	46
13 154 kg Counterweight - Fully Extended Outriggers - 360° Rotation	46
19 505 kg Counterweight - Fully Extended Outriggers - 360° Rotation	47
13 154 kg Counterweight - Fully Extended Outriggers - 360° Rotation	48
19 505 kg Counterweight - Fully Extended Outriggers - 360° Rotation	48
13 154 kg Counterweight - Fully Extended Outriggers - 360° Rotation	49
19 505 kg Counterweight - Fully Extended Outriggers - 360° Rotation	49
Metric On Tires Lift Capacity Charts – 85% – Standard	50
11 794 kg Counterweight - On Tires - Stationary - Boom Centered Over Rear Between Tire Tracks ...	50
11 794 kg Counterweight - On Tires - Pick & Carry (Creep) - Boom Centered Over Rear	50

Boom, Attachments, and Upper Structure

■ Boom

Design — Five section, formed construction of extra high tensile steel consisting of one base section and four telescoping sections. The two plate design of each section has multiple longitudinal bends for superior strength. Each telescoping section extends independently by means of one double-acting, single stage hydraulic cylinder with integral holding valves.

Boom

- 41.4–162 ft (12.6–49.3m) five section boom
- Five boom extend modes (EM1 through EM5), controlled from the operator's cab, provide superior capacities by varying the extension of the telescoping sections:
 - EM1 extends to 162.0 ft (49.3m)
 - EM2 extends to 150.0 ft (45.7m)
 - EM3 extends to 124.7 ft (38.0m)
 - EM4 extends to 112.0 ft (34.1m)
 - EM5 extends to 86.2 ft (26.3m)
- Mechanical boom angle indicator
- Maximum tip height for each extend mode is:
 - EM1 is 171 ft (52.1m)
 - EM2 is 159 ft (48.5m)
 - EM3 is 134 ft (40.8m)
 - EM4 is 122 ft (37.2m)
 - EM5 is 96 ft (29.3m)

Boom Wear Pads

- Wear pads with Teflon inserts that self-lubricate the boom sections
- Bottom wear pads are universal for all telescoping boom sections
- Bottom wear pads are universal for the boom base section
- Top wear pads are universal for all boom sections

Boom Head

- Six 16.38 in (41.6cm) root diameter nylon sheaves to handle up to twelve parts of line
- Easily removable wire rope guards
- Rope dead end lugs on each side of the boom head
- Boom head is designed for quick-reeve of the hook block

Boom Elevation

- One double acting hydraulic cylinder with integral holding valve
- Boom elevation: -2.5° to 80°

Auxiliary Lifting Sheave — Optional

- Single 16.38 in (41.6cm) root diameter nylon sheave
- Easily removable wire rope guards
- Does not affect erection of the fly or use of the main head sheaves

Hook Blocks and Balls — Optional

- 140 ton (127.0mt) 7 sheave, quick-reeve hook block with safety latch
- 100 ton (90.7mt) 6 sheave, quick-reeve hook block with safety latch
- 80 ton (72.5mt) 5 sheave, quick-reeve hook block with safety latch
- 50 ton (45.36mt) 4 sheave, quick-reeve hook block with safety latch
- 35 ton (31.7mt) 1 sheave, quick-reeve hook block with safety latch
- 12 ton (10.8mt) hook ball (swivel) with safety latch

Fly — Optional

- 31 ft–55 ft (9.4–16.8m) two piece bi-fold lattice fly, stowable, offsettable to 2° , 15° , 30° , and 45° . Maximum tip height is 225 ft (68.6m).
- 10 ft, 31 ft – 55 ft (3.0, 9.4–16.8m) three piece bi-fold lattice fly, stowable, offsettable to 2° , 15° , 30° , and 45° . Maximum tip height is 225 ft (68.6m).
- 10 ft, 31 ft – 55 ft (3.0, 9.4–16.8m) three piece bi-fold lattice fly, stowable, hydraulically offsettable from 2° through 45° . Maximum tip height is 225 ft (68.6m).

Fly Extensions — Optional

- One 18 ft (5.5m) lattice extension, equipped with two 16.38 in (41.6cm) root diameter nylon sheaves, to be mounted between the boom head and fly options. Maximum tip height is 243 ft (74.1m). Minimum of 26,000 lb (11 794kg) of counterweight required.
- Two 18 ft (5.5m) lattice extensions, one equipped with two 16.38 in (41.6cm) root diameter nylon sheaves, to be mounted between the boom head and fly options. Maximum tip height is 260 ft (79.2m). Minimum of 26,000 lb (11 794kg) of counterweight required.
- Three 18 ft (5.5m) lattice extensions, one equipped with two 16.38 in (41.6cm) root diameter nylon sheaves, to be mounted between the boom head and fly options. Maximum tip height is 278 ft (84.7m). Minimum of 29,000 lb (13 154kg) of counterweight required.

■ Operator's Cab and Controls

Environmental Cab – Fully enclosed, one person cab of galvanneal steel structure with acoustical insulation.

Equipped with:

- Tilting cab up to 20°
- Seat belt
- Tinted and tempered glass windows
- Five way adjustable, cushioned seat with headrests, and seat belt
- Extra—large fixed front window with windshield wiper and washer
- Swing up roof window with windshield wiper and washer
- Sliding left side door with large fixed window
- Sliding right side window for ventilation
- Engine dependent warm – water heater with air ducts for front windshield defroster and cab floor
- Defroster fan for the front window
- Bubble level
- Circulating fan
- Sun screen
- Dome light
- Cup holder
- Fire extinguisher
- Left side viewing mirror
- Two position travel swing lock
- AM/FM Radio

Air Conditioning – Integral with cab heating system utilizing the same ventilation outlets

Steering Column – Pedestal type with tilt and telescope functions for operator comfort. Column includes the following controls and indicators:

Left and right levers include:

- Horn button
- Turn signal switch
- Driving light switch
- Forward/Neutral/Reverse direction switch

Panel mounted switches for:

- Travel park brake
- Steer mode selector
- 2/6 wheel drive/range selector
- Hazard flasher

Panel mounted indicator/warning lights for:

- Travel park brake
- Service brake
- Turn signals
- Case filter restriction
- Charge filter restriction
- Engine overspeed
- Rear wheel offset
- Emergency steer – optional

Armrest Controls – Two dual axis electronic joystick controllers or optional single axis electronic controllers for:

- Swing
- Boom hoist
- Main front winch
- Auxiliary rear winch – optional
- Drum rotation indication
- Drum rotation indicator activation switch
- Winch high/low speed disable switch(es)
- Cab heater and A/C controls
- Throttle unlock switch
- Throttle set switch
- Cab tilt switch
- Warning horn button
- Swing park brake

Foot Controls

- Boom Telescope
- Swing brake
- Engine throttle
- Travel brake

Right Front Console – Controls and indicators for:

- Warning horn button
- Function disable switch
- Cab floodlights switch
- Console dimmer switch
- 2–12 volt accessory outlet (Switched & Unswitched)
- Emergency engine shutdown
- Windshield wiper/washer switch
- Ignition switch
- Programmable heater
- Ignition indication light
- Boom floodlights switch – optional
- Rotating beacon/strobe light switch – optional
- Luffing fly switch – optional

Camera Display – Located on dash console

- Displays right side of upper
- Displays main and auxiliary winches
- Displays rear view

Cab Instrumentation – Ergonomically positioned LCD display, CANBUS instrumentation for crane operation including:

- Tachometer
- Engine water temperature
- Fuel level
- Hydraulic oil temperature
- Travel circuit temperature
- Stop engine
- Check engine
- Wait to start
- High exhaust temperature light⁽¹⁾
- DPF regeneration light⁽¹⁾
- Regeneration Disabled light⁽¹⁾
- Swing park brake light
- Fine metering function set & %
- Engine speed
- Engine oil pressure
- Battery voltage
- Fuel rate (gal/hr)
- Engine load
- Third wrap indicator activation & setup – optional
- Engine Diagnostics
- Electronic Control Diagnostics
- DPF regeneration inhibit switch⁽¹⁾
- DPF regeneration initiate switch⁽¹⁾

⁽¹⁾ (Tier 4f / Stage IV engine only)

Diagnostic Center – Located on the left side of the front panel below the windshield

- Engine diagnostic
- RCL CANBUS diagnostic
- Crane Controller USB diagnostic
- RCL controller USB diagnostic
- Boom CANBUS diagnostic

Link-Belt Pulse – The Link-Belt in-house designed, total crane operating system that utilizes the display as a readout and operator interface for the following systems:

- **Rated capacity limiter** – LCD graphic audio – visual warning system integrated into the dash with anti – two block and function limiter. Operating data includes:
 - Crane configuration
 - Boom length
 - Boom head height
 - Allowed load and % of allowed load
 - RCL light bar
 - Boom angle
 - Radius of load
 - Actual load
 - Wind speed
 - Highlighted unit of measurement on working screen
 - Telescope operation displayed in real time
 - Counterweight installation/removal
 - Third wrap indicator
 - Diagnostics
 - Operator settable alarms (include):
 - Maximum and minimum boom angles
 - Maximum tip height
 - Maximum boom length
 - Swing left/right positions
 - Operator defined area (imaginary plane)
 - Outrigger position sensing
 - Drum rotation direction indication
 - Diagnostics
- **Internal RCL Light Bar** – Visually informs the operator when crane is approaching maximum load capacity with a series of green, yellow, and red lights.
- **Telematics** – Cellular based data logging and monitoring system that provides:
 - Location and operational settings
 - Routine maintenance
 - Crane and engine monitoring
 - Diagnostic and fault codes

Integrated Third Wrap Indicator – Optional – Link–Belt Pulse color display visually and audibly warns the operator when the wire rope is down to the last three wraps.

Integrated Third Wrap Function Kickout – Optional – Link–Belt Pulse color display visually and audibly warns the operator when the wire rope is on the first/bottom layer and provides a function kickout when the wire rope is down to the last three wraps.

External RCL Light Bar – Optional – Visually informs the ground crew when crane is approaching maximum load capacity with a series of green, yellow, and red lights.

Extend Control Module

- Controls the extend modes
- Diagnostics
- Electronic controllers
 - Controls all load lifting functions
 - Diagnostics
- Fine Metering
 - Controls the initial reaction speeds of the main and auxiliary winches, boom hoist, and swing functions.
 - Diagnostics

■ **Swing**

Motor/Planetary – Bi–directional hydraulic swing motor mounted to a planetary reducer for 360° continuous smooth swing at 1.5 rpm.

Swing Park Brake – 360°, electric over hydraulic, (spring applied/hydraulic released) multi–disc brake mounted on the speed reducer. Operated by a switch from the operator’s cab.

Swing Brake – 360°, foot operated, hydraulic applied disc brake mounted to the speed reducer.

Swing Lock – Two–position swing lock (boom over front or rear) operated from the operator’s cab.

■ **Electrical**

Swing Alarm – Audio warning device signals when the upper is swinging.

Lights

- Two LED working lights on front of the cab
- One amber strobe beacon on top of the cab
- One rotating amber beacon on top of the cab – optional
- One LED working light on top of cab – optional
- Boom floodlight – Single– optional
- Boom floodlight – Dual– optional
- Boom floodlight – High intensity remote controlled– optional

Electrical Center

- RCL by–pass switch
- Hour meter
- Battery disconnect switches
- 3 batteries provide 12 volt operation and starting
- Jumper posts
- Circuit breakers
- Outrigger position sensing CANBUS diagnostic port

Load Hoist System

Load Hoist Performance

Main (Front) and Auxiliary (Rear) Winches — 7/8 in (22mm) Rope										
Layer	Maximum Line Pull		Normal Line Speed		High Line Speed		Layer		Total	
	lb	kN	ft/min	m/min	ft/min	m/min	ft	m	ft	m
1	21,022	93.51	141	43.0	279	85.0	125	38.1	125	38.1
2	18,968	84.37	156	47.5	310	94.5	138	42.0	263	80.2
3	17,280	76.86	172	52.4	340	103.6	152	46.3	415	126.5
4	15,868	70.58	187	57.0	370	112.8	165	50.3	588	179.2
5	14,669	65.25	202	61.6	400	121.9	179	54.6	759	231.3
6	13,639	60.67	217	66.1	431	131.4	192	58.5	951	289.9

Wire Rope Application		Diameter		Type	Maximum Permissible Load	
		in	mm		lb	kg
Main (Front) Winch	Standard	7/8	22	18x19 rotation resistant — right regular lay (Type RB)	17,520	7 946.9
	Optional	7/8	22	4 strand, low torque — right regular lay (Type GC)	30,285	13 737.0
	Optional	7/8	22	36x7 rotation resistant — right regular lay (Type ZB)	20,920	9 489.2
Auxiliary (Rear) Winch	Standard	7/8	22	18x19 rotation resistant — right regular lay (Type RB)	17,520	7 946.9
	Optional	7/8	22	4 strand, low torque — right regular lay (Type GC)	30,285	13 737.0
	Optional	7/8	22	36x7 rotation resistant — right regular lay (Type ZB)	20,920	9 489.2

2M Main (Front) and Optional Auxiliary (Rear) Winches

- Axial piston, full and half displacement (2—speed) motors driven through planetary reduction unit for positive control under all load conditions.
- Grooved lagging
- Power up/down mode of operation
- Hoist drum cable follower — optional
- Drum rotation indicator
- Drum diameter: 15 in (38.1cm)
- Rope length:
 - Main (Front): 850 ft (259.0m)
 - Auxiliary (Rear): 600 ft (182.8m) or 850 ft (259.0m)
- Maximum rope storage: 951 ft (289.9m)
- Terminator style socket and wedge

Engine

Specification	Cummins QSL	
Numbers of Cylinders	6	6
Cycle	4	4
Emissions Compliance Level:	Tier 4f/Stage IV ⁽¹⁾	Tier 3/Stage IIIA ⁽²⁾
Bore and Stroke: inch (mm)	4.49 x 5.69 (114 x 145)	4.49 x 5.69 (114 x 145)
Piston Displacement: in ³ (L)	543 (8.90)	543 (8.90)
Max. Brake Horsepower: hp (kW)	345 (257) @ 2,000 rpm	350 (261) @ 1,900 rpm
	333 (248) @ 2,100 rpm	325 (242) @ 2,100 rpm
Peak Torque: ft lb (Nm)	1,050 (1 424) @ 1,500 rpm	1,050 (1 424) @ 1,500 rpm
Electric/starting systems: volts	12/12	12/12
Alternator: amps	160	160
Crankcase Capacity: qt (L)	24 (22.7)	24 (22.7)
<ul style="list-style-type: none"> • Water/fuel separator w/ heater and water in fuel (WIF) sensor • 120—volt block heater—Tier 4f/Stage IV • 240—volt block heater—Tier 3/Stage IIIA • Grid heater — 200 amp • ⁽¹⁾ Can only be sold and/or operated where Tier 4f and Stage IV off—highway emission standards are accepted. • ⁽²⁾ Can only be sold and/or operated where Tier 3 and Stage IIIA off—highway emission standards are accepted. 		

■ Drive System

Hydrostatic type consisting of two variable speed piston pumps supplying hydraulic power to six hydraulic cam lobe wheel drive motors computer controlled for smooth and reliable operation.

■ Fuel Tank

One 90 gal (340.6L) capacity tank

Diesel Exhaust Fluid (DEF) Tank

- One 10 gal (37.9L) capacity tank

■ Hydraulic System

All functions are hydraulically powered allowing positive precise control with independent or simultaneous operation of all functions.

Main Pumps

- One, two section gear pump for the boom hoist, telescope, and charge circuits.
- Two, closed—loop piston pumps serve as travel pumps. These two pumps supply hydraulic power to the wheel motors.
- Two, closed—loop piston pumps are mounted to the rear of the two travel pumps. The left pump drives the front winch and the right pump drives the optional rear winch.
- One, pressure compensated piston pump mounted to the rear of the left winch pump supplies hydraulic power to the outrigger, counterweight removal (optional), oscillation, and travel brake circuits.
- One, single section gear pump mounted to the rear of the right side winch pump supplies hydraulic power to the swing and steering circuits.
- One, single section gear pump mounted to the engine front gear train accessory drive supplies hydraulic power to the hydraulic system cooling fan motor.

Hydraulic Reservoir — 255 gal (965.3L) capacity equipped with sight level gauge. Diffuser built in for deaeration. Magnetic drain plug and large internal magnet.

Filtration

- One, 7—micron filter located inside hydraulic reservoir, accessible for easy replacement
- One, 7—micron charge filter located next to the reservoir with an in—cab indicator light
- Two, 10—micron pressure filters located next to the reservoir with change indicators
- Three, 100 mesh suction strainers located inside the hydraulic reservoir

Counterbalance Valves — Boom extend cylinder and boom hoist cylinder are equipped with counterbalance valves to provide load lowering and prevents accidental load drop when hydraulic power is suddenly reduced.

■ Pump Drive

All pumps except the hydraulic system, cooling fan, drive pump are mounted on the pump drive gearbox and mechanically driven by the diesel engine.

■ Counterweight

Standard — Total of 29,000 lb (13.1t) consisting of auxiliary winch or 2,000 lb (0.9t) top counterweight, two 12,000 lb (5.4t) and one 3,000 lb (1.3t) removable counterweights pinned to the upper with capacities for:

- 0 lb (0t) counterweight
- 14,000 lb (6.3t) counterweight
- 17,000 lb (7.7t) counterweight
- 26,000 lb (11.7t) counterweight
- 29,000 lb (13.1t) counterweight

Optional — Total of 14,000 lb (6.3t) in addition to standard counterweight for a total of 43,000 lb (19.5t) counterweight with additional capacities for:

- 43,000 lb (19.5t) counterweight*

* Overall width of the crane increases to 13 ft 4 in (4.0m) for this counterweight configuration.

Hydraulic Counterweight Removal — Optional —

Activated by a hand—held controller with enough cable to access the pins on each side of the counterweights.

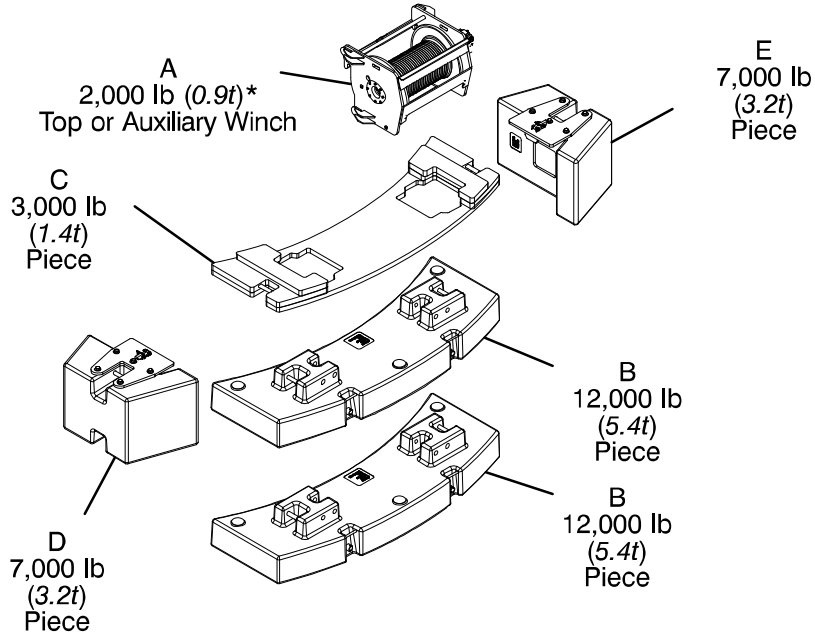

Counterweight Modules			A 2,000 lb (0.9t) Top*	B 12,000 lb (5.4t) Piece	B 12,000 lb (5.4t) Piece	C 3,000 lb (1.4t) Piece	D 7,000 lb (3.2t) Piece	E 7,000 lb (3.2t) Piece
Counterweight Usage Configurations		0 lb (0t)						
	A,B	14,000lb (6.3t)	X	X				
	A,B,C	17,000 lb (7.7t)	X	X		X		
	A,B,B	26,000 lb (11.7t)	X	X	X			
	A,B,B,C	29,000 lb (13.1t)	X	X	X	X		
	A,B,B,C,D,E	43,000 lb (19.5t)	X	X	X	X	X	X

* Auxiliary winch replaces this counterweight for a two-drum configuration

Carrier

■ General

- 9 ft 10 in (3.00m) wide
- 16 ft 1 in (4.90m) wheelbase (centerline of first axle to centerline of third axle).

Frame — Box—type, torsion resistant, welded construction made of high tensile steel. Equipped with front and rear towing and tie—down lugs, tow connections, and access ladders.

■ Outriggers

Boxes — Two removable, double box, front and rear pinned to carrier frame. Hydraulic hoses have quick—disconnect fittings for ease for box removal. Hydraulic outrigger pin removal activated by a hand—held controller — optional.

Beams and Jacks — Four single stage beams with Confined Area Lifting Capacities (CALC™) provide selectable outrigger extensions of full, intermediate, and retracted. Hydraulically controlled from the operator's cab with integral check valves.

Pontoons — Four lightweight, quick release, 26 in (0.66m) diameter, steel pontoons with contact area of 531 in² (3 425cm²) can be stored for road travel in storage racks on the carrier.

Main Jack Reaction — 160,000 lb (72 574kg) force and 301 psi (2 075.3kPa) ground bearing pressure.

■ Steering and Wheel Drive Motors

Steering — Four independent modes consisting of two wheel front, four wheel rear, six wheel, and crab. Each mode is controlled from the steering wheel and is selected by a switch in the operator's cab.

Drive — Three modes: 6x2 high, 6x2 low, and 6x6 for off highway travel

Front Drive Motors — Steered, driven for 6x2 and 6x6

Rear Drive Motors — Steered, non—driven for 6x2 and steered, driven for 6x6

■ Suspension

Front — Double “A” arms connected to oscillation cylinders that lockout when the upper structure rotates 3° past centerline of rotation.

Left Rear — Center and rear wheels mounted on double “A” arms connected to oscillation cylinders that lockout when the upper structure rotates 3° past centerline of rotation. Oscillation occurs across left center and left rear wheels.

Right Rear — Center and rear wheels mounted on double “A” arms connected to oscillation cylinders that lockout when the upper structure rotates 3° past centerline of rotation. Oscillation occurs across right center and right rear wheels.

Ride Height Adjustment — Suspension can be lowered for transport using a hand—held controller from the ground.

■ Tires and Wheels

Front and Rear — Six (single) 23.5R25, earthmover type tires on steel disc wheels

- Spare tires and wheels — optional

■ Brakes

Service — Full hydraulic, dual circuit, disc type brakes on all wheel ends

Parking/Emergency — Spring loaded type, acting on front wheel ends

■ Electrical

Lights

- Front lighting includes two main headlights and two parking/directional indicators
- Side lighting includes two parking/directional indicators per side
- Rear lighting includes two parking/directional indicators, two parking/brake lights, and two reverse lights
- Other equipment includes hazard/warning system

■ Hydraulic System

Drive System – Hydrostatic type consisting of two variable speed piston pumps supplying hydraulic power to six hydraulic cam lobe wheel drive motors computer controlled for smooth and reliable operation.

Filtration – One, 60–micron, full flow, line filter in the wheel motor case drain circuit. Filter includes an in–cab change indicator. Accessible for easy filter replacement.

■ Maximum Speed

17.1 mph (27.5 km/h)

■ Gradeability

■ Paint

Entire machine is pre-painted and oven baked with Highsolid Paint (2 part epoxy/polyester) and/or (2 part epoxy primer/2 part polyurethane top coat). Standard Link-Belt Red, Link-Belt Gray, and Gloss Black colors apply.

Counterweight	Ascending		Descending		Side	
	Degrees	% Grade	Degrees	% Grade	Degrees	% Grade
0 with outriggers removed	14.0	25%	4.0	7%	3.0	5%
0	11.0	19%	8.0	14%		
14,000 lbs (6.3t)	10.0	18%	10.0	18%		
17,000 lbs (7.7t)	10.0	18%	10.0	18%		
26,000 lbs (11.7t)	7.0	12%	9.0	16%		
29,000 lbs (13.1t)	6.0	11%	9.0	16%		
43,000 lbs (19.5t)	1.0	2%	8.0	14%		

Axle Loads – Imperial

Base machine with full tank of fuel and 29,000 lb of counterweight	Gross Vehicle Weight ⁽¹⁾	Upper Facing Front		Upper Facing Rear	
		Front Axle	Rear Axle Group	Front Axles	Rear Axle Group
	lb	lb	lb	lb	lb
Tier 4f/Stage IV	132,169	38,333	93,836	61,781	70,388
Tier 3/Stage IIIA	131,715	38,379	93,336	61,386	70,329
Operator in cab	250	154	96	39	211
Hydraulic outrigger pin removal	206	79	127	79	127
Remove outrigger boxes and beams	-17,139	-6,633	-10,505	-6,633	-10,505
Pintle hook, front	13	20	-7	20	-7
Pintle hook, rear	13	-10	23	-10	23
Hydraulic counterweight removal	312	-161	473	151	161
43,000 lb total counterweight	14,000	-7,471	21,471	18,233	-4,233
Remove 12,000 lb counterweight	-12,093	6,453	-18,546	-15,750	3,657
Remove 12,000 lb counterweight	-12,093	6,453	-18,546	-15,750	3,657
Remove 3,000 lb counterweight	-3,001	1,601	-4,602	-3,908	907
Remove 2,000 lb counterweight – for one winch configuration only	-2,017	1,304	-3,321	-2,855	838
Hoist drum follower – main	99	-49	148	125	-26
Auxiliary winch with 600 ft of wire rope	1,042	-587	1,629	1,388	-346
Remove auxiliary winch with 600 ft of wire rope – for two winch configuration only	-2,841	1,804	-4,645	-3,988	1,147
Hoist drum follower – auxiliary	101	-75	176	153	-52
Remove 850 ft of wire rope – main winch	-1,451	544	-1,994	-1,659	208
Remove 600 ft of wire rope – auxiliary winch	-1,031	590	-1,621	-1,382	352
Substitute 600 ft of wire rope with 850 ft of wire rope – auxiliary winch	420	-240	660	563	-143
360° mechanical swing lock	140	57	83	50	90
Air conditioning	86	42	44	24	62
Auxiliary lifting sheave	120	362	-242	-269	389
Boom floodlight	7	18	-11	-13	20
Fly mounting brackets to boom base for fly options	290	508	-218	-285	575
31–55 ft offsettable, two piece bi–fold fly – stowed	2,734	4,667	-1,933	-2,565	5,299
10–31–55 ft offsettable, three piece bi–fold fly – stowed	3,331	6,077	-2,746	-3,516	6,847
10–31–55 ft hydraulically offsettable, three piece bi–fold fly – stowed	3,804	7,338	-3,534	-4,414	8,218
Additional components for hydraulically offsettable fly	469	990	-521	-629	1,098
12 ton swivel hook ball (stowed at front/rear bumper)	722	1,153	-431	-598	1,320
12 ton swivel hook ball (stowed at boom head)	722	2,092	-1,370	-1,537	2,259
35 ton 1–sheave hook block (stowed at front/rear bumper)	1,100	1,756	-656	-911	2,011
35 ton 1–sheave hook block (stowed at boom head)	1,100	3,188	-2,088	-2,342	3,442
80 ton 5–sheave hook block (stowed at front/rear bumper)	1,411	2,253	-842	-1,168	2,579
80 ton 5–sheave hook block (stowed at boom head)	1,411	4,089	-2,678	-3,004	4,415
100 ton 6–sheave hook block (stowed at front/rear bumper)	1,750	2,794	-1,044	-1,449	3,199
100 ton 6–sheave hook block (stowed at boom head)	1,750	5,071	-3,321	-3,726	5,476
140 ton 7–sheave hook block (stowed at front/rear bumper)	2,394	3,822	-1,428	-1,982	4,376
140 ton 7–sheave hook block (stowed at boom head)	2,394	6,938	-4,544	-5,097	7,491
Tire	Maximum Load @ 20 mph				
23.5R25	57,330 lb				

⁽¹⁾ Adjust gross vehicle weight and axle loading according to component weight.

Note: All weights are ±3%.

Axle Loads – Metric

Base machine with full tank of fuel and 13 154.1kg of counterweight	Gross Vehicle Weight ⁽¹⁾	Upper Facing Front		Upper Facing Rear	
		Front Axle	Rear Axle Group	Front Axles	Rear Axle Group
	kg	kg	kg	kg	kg
Tier 4f/Stage IV	59 951	17 388	42 563	28 023	31 928
Tier 3/Stage IIIA	59 745	17 408	42 337	27 844	31 901
Operator in cab	113	70	44	18	96
Hydraulic outrigger pin removal	93	36	58	36	58
Remove outrigger boxes and beams	-7 774	-3 009	-4 765	-3 009	-4 765
Pintle hook, front	6	9	-3	9	-3
Pintle hook, rear	6	-4	10	-4	10
Hydraulic counterweight removal	142	-73	214	68	73
19 504.4kg total counterweight	6 350	-3 389	9 739	8 270	-1 920
Remove 5 443.1kg counterweight	-5 485	2 927	-8 412	-7 144	1 659
Remove 5 443.1kg counterweight	-5 485	2 927	-8 412	-7 144	1 659
Remove 1 360.8kg counterweight	-1 361	726	-2 088	-1 773	412
Remove 907.1kg counterweight – for one winch configuration only	-915	591	-1 506	-1 295	380
Hoist drum follower – main	45	-22	67	57	-12
Auxiliary winch with 182.8m of wire rope	473	-266	739	630	-157
Remove auxiliary winch with 182.8m of wire rope – for two winch configuration only	-1 289	818	-2 107	-1 809	520
Hoist drum follower – auxiliary	46	-34	80	69	-23
Remove 259.0kg of wire rope – main winch	-658	247	-904	-753	94
Remove 182.8m of wire rope – auxiliary winch	-468	268	-735	-627	160
Substitute 182.8m of wire rope with 259.0kg of wire rope – auxiliary winch	191	-109	299	255	-65
360° mechanical swing lock	64	26	37	23	41
Air conditioning	39	19	20	11	28
Auxiliary lifting sheave	54	164	-110	-122	176
Boom floodlight	3	8	-5	-6	9
Fly mounting brackets to boom base for fly options	132	230	-99	-129	261
9.4–16.7m offsettable, two piece bi-fold fly – stowed	1 240	2 117	-877	-1 163	2 404
3.0–9.4–16.7m offsettable, three piece bi-fold fly – stowed	1 511	2 757	-1 246	-1 595	3 106
3.0–9.4–16.7m hydraulically offsettable, three piece bi-fold fly – stowed	1 725	3 329	-1 603	-2 002	3 728
Additional components for hydraulically offsettable fly	213	449	-236	-285	498
10.8mt swivel hook ball (stowed at front/rear bumper)	327	523	-196	-271	599
10.8mt swivel hook ball (stowed at boom head)	327	949	-621	-697	1 025
31.7mt 1–sheave hook block (stowed at front/rear bumper)	499	797	-298	-413	912
31.7mt 1–sheave hook block (stowed at boom head)	499	1 446	-947	-1 062	1 561
72.5mt 5–sheave hook block (stowed at front/rear bumper)	640	1 022	-382	-530	1 170
72.5mt 5–sheave hook block (stowed at boom head)	640	1 855	-1 215	-1 363	2 003
90.7mt 6–sheave hook block (stowed at front/rear bumper)	794	1 267	-474	-657	1 451
90.7mt 6–sheave hook block (stowed at boom head)	794	2 300	-1 506	-1 690	2 484
127.0mt 7–sheave hook block (stowed at front/rear bumper)	1 086	1 734	-648	-899	1 985
127.0mt 7–sheave hook block (stowed at boom head)	1 086	3 147	-2 061	-2 312	3 398
Tire	Maximum Load @ 32.2km/h				
23.5R25	26 004kg				

(1) Adjust gross vehicle weight and axle loading according to component weight.

Note: All weights are ±3%.

Transport Configuration and Weights

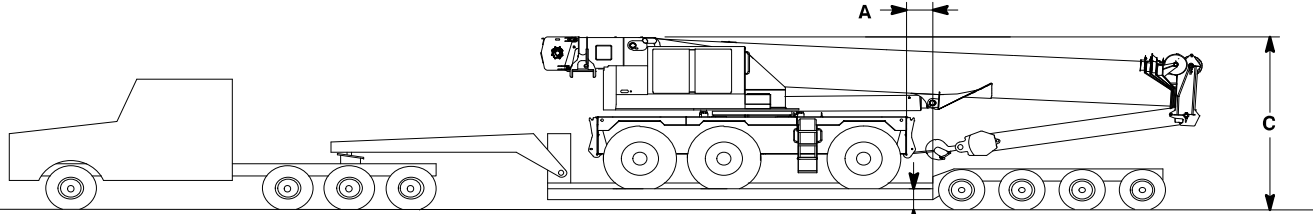

Crane Weight: 94,693 lb (42 952kg), equipped with:

- 41.4–162 ft (12.6–49.3m), five section boom
- 80 ton (72.57mt) hook block
- Main winch with 850 ft (259.1m) of 7/8 in (22mm) rope
- Auxiliary winch with 600 ft (182.8m) of 7/8 in (22mm) rope
- 10–31–55 ft (3.0–9.4–16.7m) offsettable, three piece bi-fold fly
- Hoist drum followers – Main and Auxiliary
- Auxiliary lifting sheave
- Air conditioning
- Hydraulic outrigger pin removal

Drop Off Load Weight: 45,196 lb (20 501kg)

- Two outrigger boxes with tow shackles
- 27,000 lb (12 247kg) counterweight
- 12 ton (10.9mt) hook ball

Axle Group Weights

Empty Truck Wt.	Bed Length	Steer	Drivers	Trailer	A
48,500 lb (22 000kg)	25 ft (7.62m)	12,500 lb (5 670kg)	60,138 lb (27 278kg)	70,555 lb (32 000kg)	5 in (12.7cm)

B – 18 in (0.46m) or 24 in (0.61m)

	Normal Suspension	Collapsed Suspension
C [with 18 in (0.46m) Trailer]	13 ft 11 in (4.24m)	13 ft 8 in (4.16m)
C [with 24 in (0.61m) Trailer]	14 ft 5 in (4.39m)	14 ft 2 in (4.32m)

*Wing weights 7,000 lb (6 350kg) each require additional truck.

General Dimensions

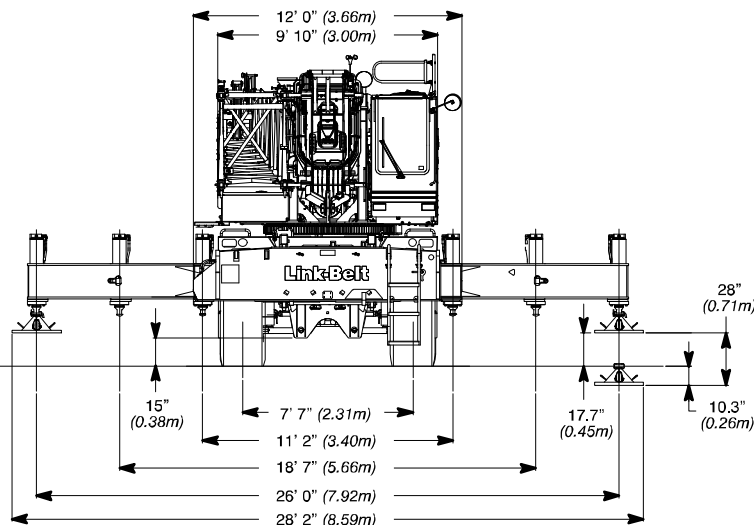
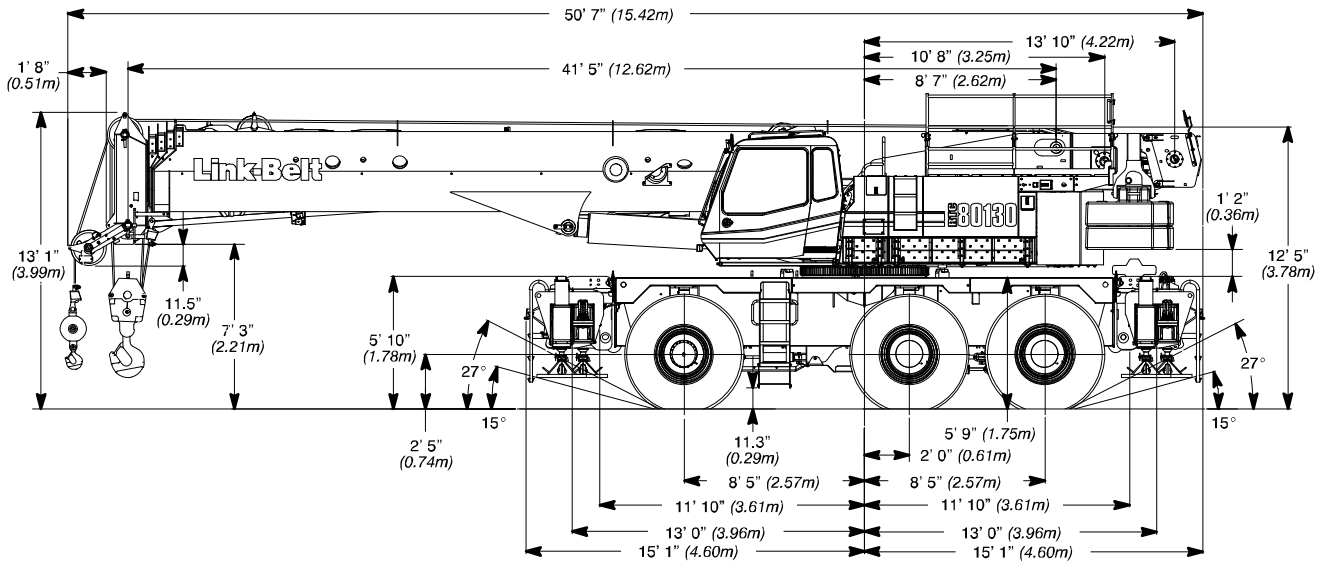

Turning Radius – 2 Wheel Steering	English	Metric
Wall to wall over carrier	44' 10"	13.67m
Wall to wall over boom attachment	56' 1"	17.09m
Curb to curb	41' 5"	12.62m
Centerline of tire	40' 4"	12.29m

Turning Radius – 6 Wheel Steering	English	Metric
Wall to wall over carrier	25' 5"	7.75m
Wall to wall over boom attachment	38' 10"	11.84m
Curb to curb	21' 10"	6.66m
Centerline of tire	20' 9"	6.32m

Tail Swing	English	Metric
of counterweight (w/o auxiliary winch)	13' 9"	3.90m
of auxiliary winch	15' 1"	4.60m

Working Range Diagram

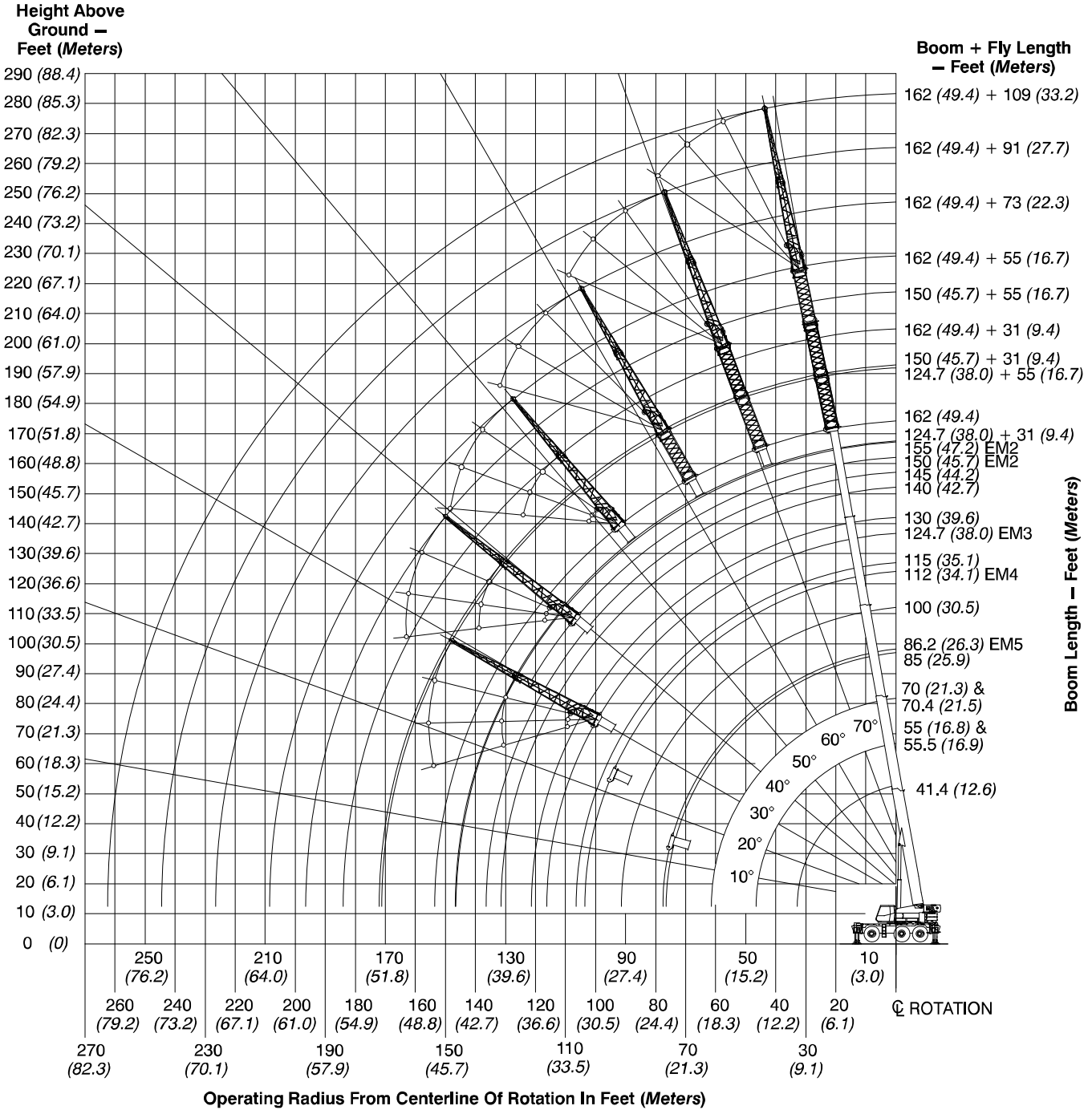

Boom Extend Modes

Boom Length		Telescope Length			
ft	m	T4	T3	T2	T1
41.4	12.6				
55	16.8	47%			
70	21.3	99%			
85	25.9	100%	49%		
100	30.5	100%	100%		
115	35.1	100%	100%	49%	
130	39.6	100%	100%	98%	
145	44.2	100%	100%	100%	46%
155	47.2	100%	100%	100%	78%
162	49.4	100%	100%	100%	100%

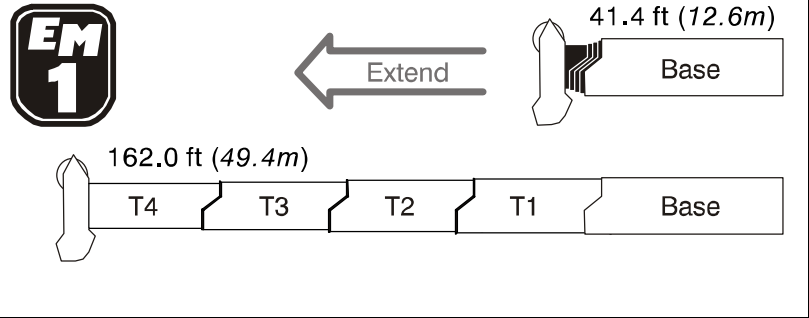

Boom Length		Telescope Length			
ft	m	T4	T3	T2	T1
41.4	12.6				
55	16.8	47%			
70	21.3	90%	9%		
85	25.9	90%	60%		
100	30.5	90%	90%	20%	
115	35.1	90%	90%	69%	
130	39.6	90%	90%	90%	27%
140	42.7	90%	90%	90%	59%
150	45.7	90%	90%	90%	90%

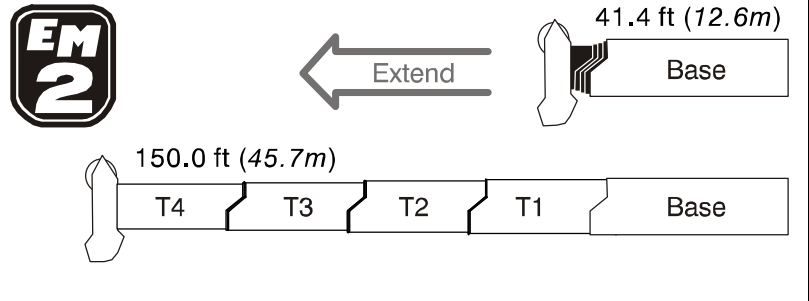

Boom Length		Telescope Length			
ft	m	T4	T3	T2	T1
41.4	12.6				
55	16.8	46%	1%		
70	21.3	46%	47%	4%	
85	25.9	46%	47%	53%	
100	30.5	46%	47%	90%	12%
115	35.1	46%	47%	90%	60%
124.7	38.0	46%	47%	90%	90%

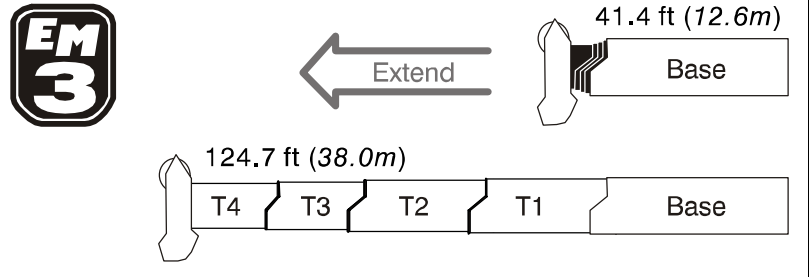

Boom Length		Telescope Length			
ft	m	T4	T3	T2	T1
41.4	12.6				
55	16.8	46%	1%		
70	21.3	46%	47%	4%	
85	25.9	46%	47%	49%	4%
100	30.5	46%	47%	49%	52%
112	34.1	46%	47%	49%	90%

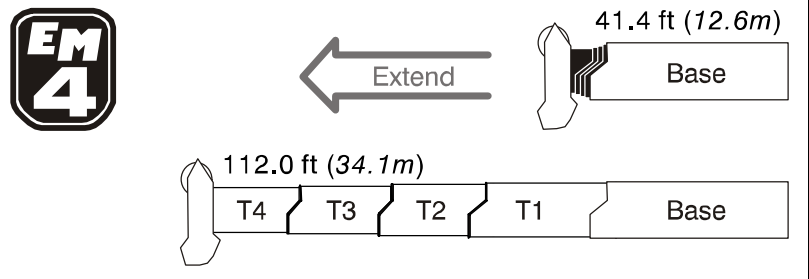

Boom Length		Telescope Length			
ft	m	T4	T3	T2	T1
41.4	12.6				
55.5	16.9		47%		
70.4	21.5		47%	49%	
86.2	26.3		47%	49%	50%

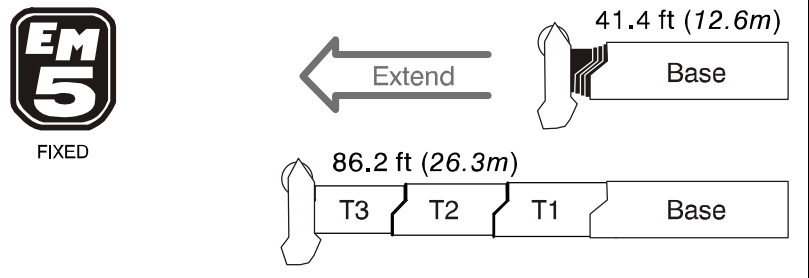

Main Boom Lift Capacity Charts – Imperial

29,000 lb Counterweight – Fully Extended Outriggers – 360° Rotation (All Capacities Are Listed In Pounds)											
Radius (ft)	Boom Length (ft)										Radius (ft)
	41.4	55	70	85	100	115	130	145	155	162	
9	*260,000										9
10	240,600	157,000	151,100								10
12	218,000	157,000	150,200								12
15	186,400	157,000	135,800	105,500							15
20	138,400	140,900	116,900	89,800	65,200	56,400					20
25	108,500	111,200	102,400	77,900	65,200	55,500	51,000				25
30	88,100	91,000	90,900	69,100	63,900	49,400	45,400	37,200			30
35		69,900	69,200	65,300	57,100	44,400	40,600	37,200	31,900	26,100	35
40		54,800	56,200	56,100	51,300	40,200	36,500	34,900	31,900	26,100	40
45		44,300	46,000	45,900	44,900	36,700	32,900	32,000	30,000	26,100	45
50			39,200	38,300	37,400	33,600	30,100	29,400	27,500	26,100	50
55			33,600	33,000	32,400	30,900	27,800	26,700	25,300	24,100	55
60			28,900	29,800	28,500	27,200	25,800	25,000	23,400	22,200	60
65				26,000	26,100	24,300	24,000	23,200	21,700	20,700	65
70				22,900	23,000	22,700	22,200	21,600	20,200	19,200	70
75				20,300	20,800	20,500	19,600	19,500	18,700	17,900	75
80					18,500	18,300	17,700	17,400	17,100	16,700	80
85					16,700	16,500	16,300	15,700	15,300	15,100	85
90					15,100	14,900	14,700	14,100	13,700	13,500	90
95						13,400	13,300	12,700	12,300	12,100	95
100							12,100	12,000	11,400	11,000	100
105								11,000	10,800	10,300	105
110									9,800	9,300	110
115										8,900	115
120											120
125											125
130											130
135											135
140											140
145											145
150											150

** Special conditions or optional equipment required

This information is not for crane operation. Operator must refer to the in-cab information for crane operation. Rated lifting capacities shown on fully extended outriggers do not exceed 85% of the tipping loads and on tires do not exceed 75% of the tipping loads.

Main Boom Lift Capacity Charts – Optional

43,000 lb Counterweight – Fully Extended Outriggers – 360° Rotation
(All Capacities Are Listed In Pounds)

Radius (ft)	Boom Length (ft)										Radius (ft)	
	41.4	55	70	85	100	115	130	145	155	162		
9	**260,000											9
10	240,600	157,000	151,100									10
12	218,000	157,000	150,200									12
15	190,700	157,000	135,800	105,500								15
20	145,500	148,100	116,900	89,800	65,200	56,400						20
25	114,400	117,100	102,400	77,900	65,200	55,500	51,000					25
30	93,200	95,900	90,900	69,100	63,900	49,400	45,400	37,200				30
35		80,600	81,300	65,300	57,100	44,400	40,600	37,200	31,900	26,100		35
40		65,800	67,300	64,900	51,300	40,200	36,500	34,900	31,900	26,100		40
45		53,600	55,200	55,000	46,500	36,700	32,900	32,000	30,000	26,100		45
50			46,400	46,400	42,400	33,600	30,100	29,400	27,500	26,100		50
55			39,500	39,700	38,700	30,900	27,800	27,100	25,300	24,100		55
60			35,100	34,400	33,600	28,600	25,800	25,000	23,400	22,200		60
65				30,100	29,300	26,500	24,000	23,200	21,700	20,700		65
70				26,800	26,400	24,600	22,500	21,600	20,200	19,200		70
75				25,100	23,400	22,900	21,000	20,300	18,700	17,900		75
80					22,000	20,400	19,800	19,000	17,400	16,700		80
85					20,400	18,900	18,600	17,800	16,200	15,600		85
90					18,500	17,800	17,600	16,700	15,100	14,600		90
95						16,800	16,300	15,700	14,100	13,500		95
100						15,500	14,900	14,600	13,100	12,600		100
105						14,200	13,500	13,500	12,300	11,800		105
110							12,300	12,300	11,500	11,000		110
115							11,600	11,200	10,800	10,300		115
120							10,800	10,300	10,000	9,600		120
125								9,400	9,100	8,900		125
130								8,600	8,300	8,100		130
135								7,900	7,500	7,300		135
140									6,900	6,600		140
145									6,200	6,000		145
150										5,500		150

**** Special conditions or optional equipment required**

This information is not for crane operation. Operator must refer to the in-cab information for crane operation. Rated lifting capacities shown on fully extended outriggers do not exceed 85% of the tipping loads and on tires do not exceed 75% of the tipping loads.

Manual Offset Fly Attachment Lift Capacity Charts – Optional

29,000 lb Counterweight – Fully Extended Outriggers – 360° Rotation (All Capacities Are Listed In Pounds)														
Radius (ft)	Main Boom + 10 ft Manual Offset Fly (2°, 15°, 30°, 45° Offsets)												Radius (ft)	
	Boom Length (ft)													
	41.4	55	70	85	100	115	124.7	130	140	145	150	155		162
10	51,800	51,800												10
12	47,300	51,800	51,800											12
15	46,400	46,800	51,800	51,800										15
20	45,200	45,700	46,000	45,800	51,800									20
25	44,600	44,900	45,100	45,000	44,300	50,700	43,400	36,300						25
30	44,600	44,400	44,500	44,400	43,800	42,800	41,600	36,300	29,900	25,600	25,400			30
35	44,600	44,300	44,100	44,000	41,300	40,100	37,300	34,100	29,900	25,600	25,400	22,400		35
40	44,600	44,300	44,000	43,700	37,500	36,400	34,000	32,200	29,900	25,600	25,400	22,400	20,000	40
45		44,300	44,000	43,500	34,500	33,400	31,000	29,500	29,500	25,600	25,400	22,400	20,000	45
50		38,700	39,100	38,700	31,800	30,600	28,300	27,100	27,100	25,600	25,400	22,400	20,000	50
55		33,000	33,400	33,000	29,400	28,200	25,700	25,100	24,900	24,200	23,300	22,400	20,000	55
60			29,300	28,400	27,300	26,000	23,500	23,200	23,000	22,500	21,500	21,200	20,000	60
65			25,900	25,100	24,300	23,500	21,500	21,600	21,300	20,900	19,800	19,600	18,700	65
70			23,000	23,100	21,900	20,500	19,800	20,100	19,700	19,400	18,400	18,100	17,000	70
75				20,600	20,300	19,100	17,600	18,800	18,400	18,100	17,200	17,100	16,300	75
80				18,400	18,100	17,900	15,600	17,100	16,900	17,100	16,000	15,900	15,100	80
85				16,600	16,400	16,300	13,700	15,400	15,000	15,300	14,600	14,800	14,100	85
90					15,000	14,600	12,100	13,900	13,400	13,700	13,000	13,300	13,000	90
95					13,600	13,200	10,700	12,900	11,900	12,200	11,600	11,800	11,600	95
100					12,300	11,900	9,500	11,600	10,700	11,000	10,300	10,600	10,300	100
105						10,800	8,300	10,500	9,600	9,800	9,200	9,400	9,200	105
110							9,800	7,300	9,500	8,500	8,800	8,200	8,400	110
115							8,900	6,500	8,600	7,600	7,900	7,300	7,500	115
120								5,600	7,700	6,800	7,100	6,400	6,700	120
125								4,900	7,000	6,100	6,300	5,700	6,000	125
130									6,300	5,400	5,700	5,000	5,300	130
135										4,800	5,000	4,400	4,700	135
140										4,200	4,400	3,800	4,100	140
145											3,900	3,300	3,600	145
150												2,800	3,000	150
155													2,600	155
160														160

This information is not for crane operation. Operator must refer to the in-cab information for crane operation. Rated lifting capacities shown on fully extended outriggers do not exceed 85% of the tipping loads and on tires do not exceed 75% of the tipping loads.

43,000 lb Counterweight – Fully Extended Outriggers – 360° Rotation (All Capacities Are Listed In Pounds)														
Radius (ft)	Main Boom + 10 ft Manual Offset Fly (2°, 15°, 30°, 45° Offsets)												Radius (ft)	
	Boom Length (ft)													
	41.4	55	70	85	100	115	124.7	130	140	145	150	155		162
10	51,800	51,800												10
12	47,300	51,800	51,800											12
15	46,400	46,800	51,800	51,800										15
20	45,200	45,700	46,000	45,800	51,800									20
25	44,600	44,900	45,100	45,000	44,300	50,700	43,400	36,300						25
30	44,600	44,400	44,500	44,400	43,800	42,800	41,600	36,300	29,900	25,600	25,400	22,400		30
35	44,600	44,300	44,100	44,000	41,300	40,100	37,300	34,100	29,900	25,600	25,400	22,400		35
40	44,600	44,300	44,000	43,700	37,500	36,400	34,000	32,200	29,900	25,600	25,400	22,400	20,000	40
45		44,300	44,000	43,500	34,500	33,400	31,000	29,500	29,500	25,600	25,400	22,400	20,000	45
50		43,600	44,000	43,500	31,800	30,600	28,300	27,100	27,100	25,600	25,400	22,400	20,000	50
55		40,000	40,400	40,000	29,400	28,200	25,700	25,100	24,900	24,200	23,300	22,400	20,000	55
60			35,100	34,700	27,300	26,000	23,500	23,200	23,000	22,500	21,500	21,200	20,000	60
65			30,900	30,500	25,400	24,100	21,500	21,600	21,300	20,900	19,800	19,600	18,700	65
70			27,300	26,900	23,700	22,400	19,800	20,100	19,700	19,400	18,400	18,100	17,000	70
75				24,000	22,200	20,900	18,200	18,800	18,400	18,100	17,200	17,100	16,300	75
80				21,500	20,900	19,500	17,000	17,600	17,200	17,100	16,000	15,900	15,100	80
85				19,600	18,800	18,100	15,700	16,700	16,200	16,000	14,900	14,800	14,100	85
90					17,300	16,400	14,600	15,700	15,200	14,900	13,900	13,800	13,100	90
95					16,500	15,000	13,500	14,800	14,200	14,000	12,900	12,900	12,200	95
100					15,400	14,200	12,500	13,900	13,300	13,100	12,000	12,000	11,400	100
105						13,400	11,600	13,200	12,500	12,400	11,100	11,200	10,600	105
110						12,700	10,400	12,000	11,600	11,600	10,300	10,400	9,900	110
115						11,800	9,400	11,000	10,600	10,800	9,600	9,700	9,200	115
120							8,400	10,000	9,600	9,900	9,000	9,000	8,500	120
125							7,600	9,100	8,700	9,000	8,300	8,400	7,900	125
130								8,700	7,900	8,200	7,600	7,800	7,400	130
135									7,200	7,500	6,800	7,100	6,800	135
140									6,500	6,800	6,200	6,400	6,200	140
145										6,200	5,500	5,800	5,600	145
150											5,000	5,200	5,000	150
155												4,700	4,500	155
160													3,900	160

This information is not for crane operation. Operator must refer to the in-cab information for crane operation. Rated lifting capacities shown on fully extended outriggers do not exceed 85% of the tipping loads and on tires do not exceed 75% of the tipping loads.

29,000 lb Counterweight – Fully Extended Outriggers – 360° Rotation
(All Capacities Are Listed In Pounds)

162 ft Main Boom Length

Radius (ft)	31 ft Manual Offset Fly				55 ft Manual Offset Fly				Radius (ft)
	2° Offset	15° Offset	30° Offset	45° Offset	2° Offset	15° Offset	30° Offset	45° Offset	
35	14,600								35
40	14,600				10,600				40
45	14,600	14,600			10,600				45
50	14,600	14,600			10,600				50
55	14,600	14,600	14,300		10,600				55
60	14,600	14,600	14,100	13,200	10,600	9,700			60
65	14,600	14,600	14,000	13,100	10,600	9,500			65
70	14,600	14,600	13,800	13,100	10,500	9,400	8,300		70
75	14,600	14,600	13,700	13,000	10,300	9,200	8,200		75
80	14,200	14,400	13,600	12,900	10,200	9,000	8,100		80
85	13,200	13,400	13,500	12,800	10,000	8,900	8,000	7,300	85
90	12,300	12,500	12,800	12,800	9,800	8,700	7,800	7,300	90
95	11,500	11,700	11,900	12,100	9,600	8,600	7,700	7,200	95
100	10,700	10,900	11,100	11,300	9,500	8,500	7,600	7,100	100
105	9,500	10,100	10,400	10,600	9,200	8,300	7,600	7,100	105
110	8,500	9,000	9,500	9,900	8,600	8,200	7,500	7,100	110
115	7,600	8,100	8,500	8,800	8,000	8,100	7,400	7,000	115
120	6,800	7,200	7,600	7,900	7,500	7,800	7,300	7,000	120
125	6,000	6,400	6,800	7,000	6,700	7,300	7,300	7,000	125
130	5,300	5,700	6,000	6,200	6,000	6,700	7,000	6,900	130
135	4,700	5,000	5,300	5,500	5,300	6,000	6,600	6,800	135
140	4,100	4,400	4,700	4,800	4,800	5,300	5,900	6,300	140
145	3,600	3,900	4,100	4,200	4,200	4,800	5,300	5,600	145
150	3,100	3,400	3,600		3,700	4,200	4,700	5,000	150
155	2,600	2,900	3,000		3,200	3,700	4,100	4,400	155
160	2,200	2,400	2,600		2,800	3,200	3,600	3,800	160
165	1,800	2,000	2,100		2,400	2,800	3,100	3,300	165
170	1,500	1,600			2,000	2,400	2,700	2,800	170
175		1,200			1,700	2,000	2,200		175
180					1,300	1,600	1,800		180
185						1,300	1,500		185

This information is not for crane operation. Operator must refer to the in-cab information for crane operation. Rated lifting capacities shown on fully extended outriggers do not exceed 85% of the tipping loads and on tires do not exceed 75% of the tipping loads.

43,000 lb Counterweight – Fully Extended Outriggers – 360° Rotation
(All Capacities Are Listed In Pounds)

162 ft Main Boom Length

Radius (ft)	31 ft Manual Offset Fly				55 ft Manual Offset Fly				Radius (ft)
	2° Offset	15° Offset	30° Offset	45° Offset	2° Offset	15° Offset	30° Offset	45° Offset	
35	14,600								35
40	14,600				10,600				40
45	14,600	14,600			10,600				45
50	14,600	14,600			10,600				50
55	14,600	14,600	14,300		10,600				55
60	14,600	14,600	14,100	13,200	10,600	9,700			60
65	14,600	14,600	14,000	13,100	10,600	9,500			65
70	14,600	14,600	13,800	13,100	10,500	9,400	8,300		70
75	14,600	14,600	13,700	13,000	10,300	9,200	8,200		75
80	14,200	14,400	13,600	12,900	10,200	9,000	8,100		80
85	13,200	13,400	13,500	12,800	10,000	8,900	8,000	7,300	85
90	12,300	12,500	12,800	12,800	9,800	8,700	7,800	7,300	90
95	11,500	11,700	11,900	12,100	9,600	8,600	7,700	7,200	95
100	10,700	10,900	11,100	11,300	9,500	8,500	7,600	7,100	100
105	10,000	10,200	10,400	10,600	9,200	8,300	7,600	7,100	105
110	9,400	9,600	9,800	9,900	8,600	8,200	7,500	7,100	110
115	8,800	8,900	9,100	9,300	8,000	8,100	7,400	7,000	115
120	8,200	8,400	8,600	8,700	7,500	7,800	7,300	7,000	120
125	7,700	7,800	8,000	8,100	7,000	7,300	7,300	7,000	125
130	7,200	7,300	7,500	7,600	6,600	6,800	7,000	6,900	130
135	6,700	6,900	7,000	7,100	6,100	6,300	6,600	6,800	135
140	6,300	6,400	6,600	6,700	5,700	5,900	6,100	6,300	140
145	5,800	6,000	6,100	6,200	5,300	5,500	5,700	5,900	145
150	5,300	5,500	5,700		5,000	5,200	5,400	5,500	150
155	4,700	5,000	5,100		4,600	4,800	5,000	5,100	155
160	4,200	4,400	4,600		4,300	4,500	4,700	4,800	160
165	3,800	4,000	4,100		4,000	4,200	4,300	4,400	165
170	3,400	3,500	3,600		3,800	3,900	4,000	4,100	170
175	3,000	3,100			3,500	3,600	3,700		175
180	2,600	2,700			3,100	3,400	3,500		180
185					2,800	3,000	3,200		185
190					2,400	2,600	2,800		190
195					2,100	2,300	2,400		195
200					1,800	2,000			200
205					1,600	1,600			205

This information is not for crane operation. Operator must refer to the in-cab information for crane operation. Rated lifting capacities shown on fully extended outriggers do not exceed 85% of the tipping loads and on tires do not exceed 75% of the tipping loads.

29,000 lb Counterweight – Fully Extended Outriggers – 360° Rotation (All Capacities Are Listed In Pounds)													
162 ft Main Boom Length													
Radius (ft)	73 ft Manual Offset Fly				91 ft Manual Offset Fly				109 ft Manual Offset Fly				Radius (ft)
	2° Offset	15° Offset	30° Offset	45° Offset	2° Offset	15° Offset	30° Offset	45° Offset	2° Offset	15° Offset	30° Offset	45° Offset	
55	8,500												55
60	8,500				6,500								60
65	8,500				6,500				5,000				65
70	8,500	8,500			6,500				5,000				70
75	8,500	8,500			6,500	6,500			5,000				75
80	8,500	8,500			6,500	6,500			5,000				80
85	8,500	8,400	7,600		6,500	6,500			5,000	5,000			85
90	8,500	8,300	7,500		6,500	6,500	6,100		5,000	5,000			90
95	8,500	8,200	7,500	6,800	6,500	6,500	5,900		5,000	4,900			95
100	8,500	8,100	7,400	6,600	6,500	6,300	5,600	5,200	5,000	4,600	4,200		100
105	8,500	8,000	7,100	6,400	6,500	6,000	5,400	5,000	4,700	4,400	4,000		105
110	8,000	7,900	6,900	6,300	6,400	5,800	5,200	4,800	4,500	4,100	3,800	3,500	110
115	7,400	7,700	6,700	6,100	6,100	5,500	5,000	4,600	4,200	3,900	3,600	3,400	115
120	6,900	7,100	6,500	6,000	5,800	5,300	4,800	4,500	4,000	3,700	3,400	3,200	120
125	6,400	6,600	6,300	5,800	5,500	5,100	4,600	4,300	3,800	3,500	3,200	3,000	125
130	5,800	6,200	6,200	5,700	5,100	4,900	4,400	4,200	3,600	3,300	3,000	2,900	130
135	5,100	5,700	6,000	5,600	4,700	4,700	4,300	4,000	3,400	3,200	2,900	2,700	135
140	4,500	5,100	5,600	5,500	4,300	4,500	4,100	3,900	3,200	3,000	2,700	2,600	140
145	4,000	4,500	5,100	5,400	3,900	4,200	4,000	3,800	3,100	2,800	2,600	2,400	145
150	3,500	4,000	4,500	4,900	3,400	3,900	3,900	3,700	2,900	2,700	2,500	2,300	150
155	3,000	3,400	4,000	4,300	2,900	3,400	3,700	3,600	2,600	2,600	2,300	2,200	155
160	2,500	3,000	3,500	3,800	2,400	2,900	3,500	3,500	2,300	2,400	2,200	2,100	160
165	2,100	2,500	3,000	3,300	2,000	2,500	3,000	3,300	1,900	2,200	2,100	2,000	165
170	1,800	2,100	2,500	2,800	1,600	2,100	2,500	2,800	1,500	2,000	2,000	1,900	170
175	1,400	1,700	2,100	2,300	1,300	1,700	2,100	2,400		1,600	1,900	1,800	175
180		1,400	1,700	1,900		1,300	1,700	1,900		1,200	1,700	1,700	180
185			1,300	1,500			1,300	1,500			1,300	1,500	185
190												1,200	190

This information is not for crane operation. Operator must refer to the in-cab information for crane operation. Rated lifting capacities shown on fully extended outriggers do not exceed 85% of the tipping loads and on tires do not exceed 75% of the tipping loads.

43,000 lb Counterweight — Fully Extended Outriggers — 360° Rotation (All Capacities Are Listed In Pounds)													
162 ft Main Boom Length													
Radius (ft)	73 ft Manual Offset Fly				91 ft Manual Offset Fly				109 ft Manual Offset Fly				Radius (ft)
	2° Offset	15° Offset	30° Offset	45° Offset	2° Offset	15° Offset	30° Offset	45° Offset	2° Offset	15° Offset	30° Offset	45° Offset	
55	8,500												55
60	8,500				6,500								60
65	8,500				6,500				5,000				65
70	8,500	8,500			6,500				5,000				70
75	8,500	8,500			6,500	6,500			5,000				75
80	8,500	8,500			6,500	6,500			5,000				80
85	8,500	8,400	7,600		6,500	6,500			5,000	5,000			85
90	8,500	8,300	7,500		6,500	6,500	6,100		5,000	5,000			90
95	8,500	8,200	7,500	6,800	6,500	6,500	5,900		5,000	4,900			95
100	8,500	8,100	7,400	6,600	6,500	6,300	5,600	5,200	5,000	4,600	4,200		100
105	8,500	8,000	7,100	6,400	6,500	6,000	5,400	5,000	4,700	4,400	4,000		105
110	8,000	7,900	6,900	6,300	6,400	5,800	5,200	4,800	4,500	4,100	3,800	3,500	110
115	7,400	7,700	6,700	6,100	6,100	5,500	5,000	4,600	4,200	3,900	3,600	3,400	115
120	6,900	7,100	6,500	6,000	5,800	5,300	4,800	4,500	4,000	3,700	3,400	3,200	120
125	6,400	6,600	6,300	5,800	5,500	5,100	4,600	4,300	3,800	3,500	3,200	3,000	125
130	6,000	6,200	6,200	5,700	5,100	4,900	4,400	4,200	3,600	3,300	3,000	2,900	130
135	5,500	5,800	6,000	5,600	4,700	4,700	4,300	4,000	3,400	3,200	2,900	2,700	135
140	5,100	5,400	5,600	5,500	4,300	4,500	4,100	3,900	3,200	3,000	2,700	2,600	140
145	4,800	5,000	5,200	5,400	4,000	4,200	4,000	3,800	3,100	2,800	2,600	2,400	145
150	4,400	4,600	4,800	5,000	3,600	3,900	3,900	3,700	2,900	2,700	2,500	2,300	150
155	4,100	4,300	4,500	4,700	3,300	3,500	3,700	3,600	2,600	2,600	2,300	2,200	155
160	3,700	3,900	4,100	4,300	3,000	3,200	3,500	3,500	2,300	2,400	2,200	2,100	160
165	3,400	3,600	3,800	4,000	2,700	2,900	3,200	3,400	2,000	2,200	2,100	2,000	165
170	3,200	3,300	3,500	3,700	2,500	2,700	2,900	3,100	1,800	2,000	2,000	1,900	170
175	2,900	3,000	3,200	3,300	2,200	2,400	2,600	2,800	1,500	1,700	1,900	1,800	175
180	2,600	2,800	2,900	3,000	2,000	2,100	2,300	2,500	1,300	1,500	1,700	1,700	180
185	2,400	2,500	2,700	2,800	1,700	1,900	2,100	2,200		1,200	1,400	1,600	185
190	2,100	2,300	2,400	2,500	1,500	1,700	1,800	1,900			1,200	1,300	190
195	1,800	2,000	2,200		1,300	1,400	1,600	1,700					195
200	1,500	1,700	1,900			1,200	1,400	1,400					200
205	1,200	1,400	1,500					1,200					205
210			1,200										210

This information is not for crane operation. Operator must refer to the in-cab information for crane operation. Rated lifting capacities shown on fully extended outriggers do not exceed 85% of the tipping loads and on tires do not exceed 75% of the tipping loads.

Hydraulic Offset Fly Attachment Lift Capacity Charts – Optional

29,000 lb Counterweight – Fully Extended Outriggers – 360° Rotation (All Capacities Are Listed In Pounds)														
Main Boom + 10 ft Hydraulic Offset Fly (2°–45° Offsets)														
Radius (ft)	Main Boom Length (ft)													Radius (ft)
	41.1	55.0	70.0	85.0	100.0	115.0	124.7	130.0	140.0	145.0	150.0	155.0	162.0	
10	51,800	51,800												10
12	47,200	51,800	51,800											12
15	46,200	46,700	51,800	51,800										15
20	45,000	45,500	45,800	45,600	51800									20
25	44,400	44,700	45,000	44,900	44200	50,300	43,300	36,100						25
30	43,800	44,200	44,400	44,300	43600	42,700	41,200	36,100	29,800	25,400	25,300	22,300		30
35	42,100	44,100	44,000	43,800	40900	39,700	36,900	33,800	29,800	25,400	25,300	22,300		35
40	42,100	43,000	43,800	43,500	37100	36,000	33,600	31,800	29,800	25,400	25,300	22,300	19,900	40
45		41,900	43,700	43,400	34200	33,000	30,600	29,100	29,100	25,400	25,300	22,300	19,900	45
50		38,400	38,800	38,400	31400	30,200	27,900	26,700	26,700	25,400	25,000	22,300	19,900	50
55		32,600	33,100	32,700	29000	27,800	25,300	24,700	24,500	23,800	22,900	22,300	19,900	55
60			28,900	28,100	26900	25,600	23,100	22,800	22,600	22,100	21,100	20,800	19,900	60
65			25,500	24,700	23900	23,200	21,100	21,200	20,900	20,500	19,400	19,200	18,300	65
70			22,600	22,800	21500	20,100	19,300	19,700	19,300	19,000	17,900	17,700	16,900	70
75				20,200	19,900	18,700	17,200	18,400	17,900	17,600	16,800	16,700	15,900	75
80				18,000	17,800	17,400	15,200	16,900	16,500	16,700	15,600	15,500	14,700	80
85				16,200	16,000	15,900	13,400	15,100	14,600	14,900	14,200	14,400	13,600	85
90					14,700	14,300	11,700	13,500	13,000	13,300	12,600	12,900	12,600	90
95					13,200	12,800	10,300	12,500	11,600	11,800	11,200	11,500	11,200	95
100					12,000	11,600	9,100	11,200	10,300	10,600	9,900	10,200	9,900	100
105						10,400	8,000	10,100	9,200	9,500	8,800	9,100	8,800	105
110						9,400	7,000	9,100	8,200	8,400	7,800	8,100	7,800	110
115						8,500	6,100	8,200	7,300	7,500	6,900	7,100	6,900	115
120							5,200	7,400	6,400	6,700	6,100	6,300	6,100	120
125							4,500	6,600	5,700	6,000	5,300	5,600	5,300	125
130								5,900	5,000	5,300	4,600	4,900	4,700	130
135									4,400	4,700	4,000	4,300	4,000	135
140									3,800	4,100	3,500	3,700	3,500	140
145										3,600	2,900	3,200	2,900	145
150											2,400	2,700	2,500	150
155												2,200	2,000	155
160													1,500	160

This information is not for crane operation. Operator must refer to the in-cab information for crane operation. Rated lifting capacities shown on fully extended outriggers do not exceed 85% of the tipping loads and on tires do not exceed 75% of the tipping loads.

43,000 lb Counterweight – Fully Extended Outriggers – 360° Rotation (All Capacities Are Listed In Pounds)														
Main Boom + 10 ft Hydraulic Offset Fly (2°–45° Offsets)														
Radius (ft)	Main Boom Length (ft)												Radius (ft)	
	41.1	55.0	70.0	85.0	100.0	115.0	124.7	130.0	140.0	145.0	150.0	155.0		162.0
10	51,800	51,800												10
12	47,200	51,800	51,800											12
15	46,200	46,700	51,800	51,800										15
20	45,000	45,500	45,800	45,600	51,800									20
25	44,400	44,700	45,000	44,900	44,200	50,300	43,300	36,100						25
30	43,800	44,200	44,400	44,300	43,600	42,700	41,200	36,100	29,800	25,400	25,300	22,300		30
35	42,100	44,100	44,000	43,800	40,900	39,700	36,900	33,800	29,800	25,400	25,300	22,300		35
40	42,100	43,000	43,800	43,500	37,100	36,000	33,600	31,800	29,800	25,400	25,300	22,300	19,900	40
45		41,900	43,700	43,400	34,200	33,000	30,600	29,100	29,100	25,400	25,300	22,300	19,900	45
50		41,700	42,600	43,400	31,400	30,200	27,900	26,700	26,700	25,400	25,000	22,300	19,900	50
55		39,700	40,000	39,600	29,000	27,800	25,300	24,700	24,500	23,800	22,900	22,300	19,900	55
60			34,800	34,400	26,900	25,600	23,100	22,800	22,600	22,100	21,100	20,800	19,900	60
65			30,500	30,100	25,000	23,700	21,100	21,200	20,900	20,500	19,400	19,200	18,300	65
70			27,000	26,600	23,300	22,000	19,300	19,700	19,300	19,000	17,900	17,700	16,900	70
75				23,600	21,800	20,500	17,800	18,400	17,900	17,600	16,800	16,700	15,900	75
80				21,100	20,400	19,100	16,600	17,200	16,900	16,700	15,600	15,500	14,700	80
85				19,200	18,500	17,700	15,300	16,300	15,800	15,500	14,500	14,400	13,600	85
90					17,000	16,000	14,100	15,300	14,700	14,500	13,500	13,400	12,700	90
95					16,100	14,600	13,000	14,400	13,800	13,600	12,500	12,500	11,800	95
100					15,100	13,800	12,100	13,500	12,900	12,700	11,500	11,600	11,000	100
105						13,000	11,200	12,800	12,100	11,900	10,700	10,800	10,200	105
110						12,300	10,000	11,700	11,200	11,200	9,900	10,000	9,500	110
115						11,400	9,000	10,600	10,200	10,500	9,200	9,300	8,800	115
120							8,000	9,700	9,200	9,500	8,500	8,600	8,100	120
125							7,200	8,800	8,400	8,600	7,900	8,000	7,500	125
130								8,300	7,600	7,800	7,200	7,400	6,900	130
135									6,800	7,100	6,500	6,700	6,400	135
140									6,200	6,400	5,800	6,000	5,800	140
145										5,800	5,200	5,400	5,200	145
150											4,600	4,800	4,600	150
155												4,300	4,100	155
160													3,500	160

This information is not for crane operation. Operator must refer to the in-cab information for crane operation. Rated lifting capacities shown on fully extended outriggers do not exceed 85% of the tipping loads and on tires do not exceed 75% of the tipping loads.

29,000 lb Counterweight – Fully Extended Outriggers – 360° Rotation (All Capacities Are Listed In Pounds)							
162 ft Main Boom Length							
Radius (ft)	31 ft Hydraulic Offset Fly			55 ft Hydraulic Offset Fly			Radius (ft)
	2°–15°	15°–30°	30°–45°	2°–15°	15°–30°	30°–45°	
40	14,400	14,400					40
45	14,400	14,400		10,400			45
50	14,400	14,200	14,200	10,400			50
55	14,400	14,100	13,100	10,400			55
60	14,400	13,900	12,900	9,500	9,500		60
65	14,400	13,800	12,700	9,300	9,300		65
70	14,400	13,600	12,600	9,100	9,100		70
75	14,400	13,500	12,500	9,000	7,900	7,900	75
80	13,300	13,300	12,300	8,800	7,800	6,700	80
85	12,300	12,500	12,200	8,600	7,700	6,600	85
90	11,400	11,600	11,900	8,500	7,600	6,500	90
95	10,600	10,800	11,100	8,400	7,500	6,500	95
100	9,800	10,000	10,300	8,200	7,400	6,400	100
105	9,100	9,300	9,500	8,100	7,300	6,300	105
110	8,200	8,700	8,900	7,700	7,200	6,200	110
115	7,300	7,800	8,200	7,200	7,200	6,200	115
120	6,400	6,900	7,300	6,600	6,900	6,100	120
125	5,700	6,100	6,500	6,100	6,400	6,100	125
130	5,000	5,400	5,700	5,700	5,900	6,100	130
135	4,400	4,700	5,000	5,100	5,500	5,700	135
140	3,800	4,100	4,400	4,500	5,100	5,300	140
145	3,300	3,600	3,800	3,900	4,500	4,900	145
150	2,800	3,000	3,200	3,400	3,900	4,400	150
155	2,300	2,500	2,700	3,000	3,400	3,900	155
160	1,900	2,100	2,200	2,500	3,000	3,400	160
165	1,500	1,700	1,700	2,100	2,500	2,900	165
170		1,300	1,300	1,700	2,100	2,400	170
175				1,400	1,700	2,000	175
180					1,300	1,600	180

This information is not for crane operation. Operator must refer to the in-cab information for crane operation. Rated lifting capacities shown on fully extended outriggers do not exceed 85% of the tipping loads and on tires do not exceed 75% of the tipping loads.

43,000 lb Counterweight – Fully Extended Outriggers – 360° Rotation (All Capacities Are Listed In Pounds)							
162 ft Main Boom Length							
Radius (ft)	31 ft Hydraulic Offset Fly			55 ft Hydraulic Offset Fly			Radius (ft)
	2°–15°	15°–30°	30°–45°	2°–15°	15°–30°	30°–45°	
40	14,400	14,400					40
45	14,400	14,400		10,400			45
50	14,400	14,200	14,200	10,400			50
55	14,400	14,100	13,100	10,400			55
60	14,400	13,900	12,900	9,500	9,500		60
65	14,400	13,800	12,700	9,300	9,300		65
70	14,400	13,600	12,600	9,100	9,100		70
75	14,400	13,500	12,500	9,000	7,900	7,900	75
80	13,300	13,300	12,300	8,800	7,800	6,700	80
85	12,300	12,500	12,200	8,600	7,700	6,600	85
90	11,400	11,600	11,900	8,500	7,600	6,500	90
95	10,600	10,800	11,100	8,400	7,500	6,500	95
100	9,800	10,000	10,300	8,200	7,400	6,400	100
105	9,100	9,300	9,500	8,100	7,300	6,300	105
110	8,500	8,700	8,900	7,700	7,200	6,200	110
115	7,900	8,100	8,200	7,200	7,200	6,200	115
120	7,300	7,500	7,700	6,600	6,900	6,100	120
125	6,800	6,900	7,100	6,100	6,400	6,100	125
130	6,300	6,400	6,600	5,700	5,900	6,100	130
135	5,800	6,000	6,100	5,300	5,500	5,700	135
140	5,400	5,500	5,700	4,800	5,100	5,300	140
145	4,900	5,100	5,200	4,500	4,700	4,900	145
150	4,500	4,700	4,800	4,100	4,300	4,500	150
155	4,100	4,300	4,400	3,800	4,000	4,100	155
160	3,800	3,900	4,000	3,400	3,600	3,800	160
165	3,400	3,500	3,600	3,100	3,300	3,500	165
170	3,000	3,200	3,200	2,900	3,000	3,100	170
175	2,600	2,700		2,600	2,700	2,900	175
180	2,300	2,300		2,300	2,500	2,600	180
185				2,000	2,200	2,300	185
190				1,800	1,900	2,000	190
195				1,600	1,700		195
200				1,400	1,500		200
205				1,300			205

This information is not for crane operation. Operator must refer to the in-cab information for crane operation. Rated lifting capacities shown on fully extended outriggers do not exceed 85% of the tipping loads and on tires do not exceed 75% of the tipping loads.

29,000 lb Counterweight – Fully Extended Outriggers – 360° Rotation
(All Capacities Are Listed In Pounds)

162 ft Main Boom Length

Radius (ft)	73 ft Hydraulic Offset Fly			91 ft Hydraulic Offset Fly			109 ft Hydraulic Offset Fly			Radius (ft)
	2°–15°	15°–30°	30°–45°	2°–15°	15°–30°	30°–45°	2°–15°	15°–30°	30°–45°	
55	8,300									55
60	8,300			6,300						60
65	8,300	8,300		6,300			4,800			65
70	8,300	8,300		6,300			4,800			70
75	8,300	8,300		6,300	6,300		4,800			75
80	8,200	7,500	7,500	6,300	6,300		4,800	4,900		80
85	8,100	7,400	7,400	6,300	6,300		4,600	4,600		85
90	8,000	7,100	6,200	6,100	5,300	5,300	4,300	4,300		90
95	7,900	6,900	6,000	5,800	5,100	5,100	4,000	3,500	3,500	95
100	7,800	6,600	5,800	5,500	4,800	4,400	3,700	3,300	3,300	100
105	7,500	6,400	5,700	5,200	4,600	4,200	3,400	3,100	2,800	105
110	7,100	6,200	5,500	4,900	4,400	4,000	3,200	2,800	2,600	110
115	6,500	5,900	5,300	4,700	4,100	3,800	3,000	2,600	2,400	115
120	6,000	5,800	5,200	4,500	3,900	3,600	2,800	2,400	2,200	120
125	5,500	5,600	5,100	4,300	3,800	3,400	2,600	2,200	2,000	125
130	5,100	5,300	4,900	4,100	3,600	3,300	2,400	2,100	1,900	130
135	4,600	4,900	4,800	3,800	3,400	3,200	2,200	1,900	1,700	135
140	4,200	4,500	4,700	3,400	3,300	3,000	2,000	1,700	1,500	140
145	3,700	4,100	4,300	3,000	3,100	2,900	1,900	1,600	1,400	145
150	3,200	3,700	4,000	2,700	2,900	2,800	1,700	1,400	1,200	150
155	2,700	3,200	3,600	2,400	2,600	2,700	1,600	1,300		155
160	2,200	2,700	3,200	2,100	2,300	2,600	1,300			160
165	1,800	2,300	2,700	1,700	2,000	2,200				165
170	1,500	1,800	2,300	1,300	1,700	1,900				170
175		1,500	1,800		1,400	1,600				175
180			1,400			1,400				180

This information is not for crane operation. Operator must refer to the in-cab information for crane operation. Rated lifting capacities shown on fully extended outriggers do not exceed 85% of the tipping loads and on tires do not exceed 75% of the tipping loads.

43,000 lb Counterweight – Fully Extended Outriggers – 360° Rotation (All Capacities Are Listed In Pounds)										
162 ft Main Boom Length										
Radius (ft)	73 ft Hydraulic Offset Fly			91 ft Hydraulic Offset Fly			109 ft Hydraulic Offset Fly			Radius (ft)
	2°–15°	15°–30°	30°–45°	2°–15°	15°–30°	30°–45°	2°–15°	15°–30°	30°–45°	
55	8,300									55
60	8,300			6,300						60
65	8,300	8,300		6,300			4,800			65
70	8,300	8,300		6,300			4,800			70
75	8,300	8,300		6,300	6,300		4,800			75
80	8,200	7,500	7,500	6,300	6,300		4,800	4,900		80
85	8,100	7,400	7,400	6,300	6,300		4,600	4,600		85
90	8,000	7,100	6,200	6,100	5,300	5,300	4,300	4,300		90
95	7,900	6,900	6,000	5,800	5,100	5,100	4,000	3,500	3,500	95
100	7,800	6,600	5,800	5,500	4,800	4,400	3,700	3,300	3,300	100
105	7,500	6,400	5,700	5,200	4,600	4,200	3,400	3,100	2,800	105
110	7,100	6,200	5,500	4,900	4,400	4,000	3,200	2,800	2,600	110
115	6,500	5,900	5,300	4,700	4,100	3,800	3,000	2,600	2,400	115
120	6,000	5,800	5,200	4,500	3,900	3,600	2,800	2,400	2,200	120
125	5,500	5,600	5,100	4,300	3,800	3,400	2,600	2,200	2,000	125
130	5,100	5,300	4,900	4,100	3,600	3,300	2,400	2,100	1,900	130
135	4,600	4,900	4,800	3,800	3,400	3,200	2,200	1,900	1,700	135
140	4,200	4,500	4,700	3,400	3,300	3,000	2,000	1,700	1,500	140
145	3,900	4,100	4,300	3,000	3,100	2,900	1,900	1,600	1,400	145
150	3,500	3,700	4,000	2,700	2,900	2,800	1,700	1,400	1,200	150
155	3,200	3,400	3,600	2,400	2,600	2,700	1,600	1,300		155
160	2,800	3,000	3,300	2,100	2,300	2,600	1,300			160
165	2,500	2,700	2,900	1,800	2,000	2,200				165
170	2,200	2,400	2,600	1,500	1,700	1,900				170
175	2,000	2,100	2,300	1,200	1,400	1,600				175
180	1,700	1,900	2,000			1,400				180
185	1,500	1,600	1,800							185
190	1,200	1,300	1,500							190
195			1,200							195

This information is not for crane operation. Operator must refer to the in-cab information for crane operation. Rated lifting capacities shown on fully extended outriggers do not exceed 85% of the tipping loads and on tires do not exceed 75% of the tipping loads.

On Tires Lift Capacity Charts – Imperial

26,000 lb Counterweight – On Tires – Stationary – Boom Centered Over Rear Between Tire Tracks (All Capacities Are Listed In Pounds)								
Radius (ft)	Boom Length (ft)							Radius (ft)
	41.4	55	70	85	100	115	130	
10	92,000							10
12	71,900							12
15	60,900	51,000						15
20	47,900	51,000	32,900					20
25	37,500	41,600	32,900	26,200				25
30	26,700	30,600	32,900	26,200	21,500			30
35		23,300	25,600	26,200	21,500	17,400		35
40		18,200	20,400	21,100	21,500	17,400	13,500	40
45		14,500	16,700	17,300	17,700	17,400	13,500	45
50			13,700	14,400	14,900	14,700	13,500	50
55			11,400	12,000	12,500	12,400	12,200	55
60			9,500	10,100	10,600	10,400	10,300	60
65				8,600	9,000	8,800	8,700	65
70				7,200	7,600	7,500	7,400	70
75				6,100	6,500	6,400	6,200	75
80					5,500	5,400	5,300	80
85					4,700	4,500	4,400	85
90					3,900	3,800	3,600	90
95						3,100	3,000	95
100						2,500	2,400	100
105						2,000	1,900	105

26,000 lb Counterweight – On Tires – Pick & Carry (Creep) – Boom Centered Over Rear (All Capacities Are Listed In Pounds)								
Radius (ft)	Boom Length (ft)							Radius (ft)
	41.4	55	70	85	100	115	130	
10	88,800							10
12	71,900							12
15	60,900	48,500						15
20	44,300	48,500	26,800					20
25	29,700	33,600	26,800	21,500				25
30	20,900	24,600	26,800	21,500	17,600			30
35		18,600	20,800	21,500	17,600	14,300		35
40		14,500	16,600	17,300	17,600	14,300	11,700	40
45		11,300	13,300	1,400	14,500	14,300	11,700	45
50			10,800	11,500	12,000	11,800	11,700	50
55			8,800	9,500	10,000	9,800	9,700	55
60			7,200	7,900	8,300	8,200	8,100	60
65				6,500	6,900	6,800	6,700	65
70				5,400	5,800	5,600	5,500	70
75				4,400	4,800	4,700	4,500	75
80					3,900	3,800	3,700	80
85					3,200	3,000	2,900	85
90					2,600	2,400	2,300	90
95						1,800	1,700	95

This information is not for crane operation. Operator must refer to the in-cab information for crane operation. Rated lifting capacities shown on fully extended outriggers do not exceed 85% of the tipping loads and on tires do not exceed 75% of the tipping loads.

Metric Main Boom Lift Capacity Charts – 75% – Standard

13 154 kg Counterweight - Fully Extended Outriggers - 360° Rotation (All Capacities Are Listed In kilograms)														
Radius (m)	Boom Length (m)											Radius (m)		
	12.61	16.8-16.9*	21.3-21.5*	25.9-26.27*	30.5	34.14-35.1*	38.01-39.6*	42.7	44.2	45.72	47.2		49.38	
2.5	**120 000													2.5
3	110 050	71 200	68 500											3
3.5	101 400	71 200	68 500											3.5
4	93 950	71 200	65 600											4
4.5	85 900	71 200	62 050	47 850										4.5
5	77 200	71 200	58 900	45 700										5
6	63 800	64 950	53 450	41 150	29 550	25 550								6
7	54 050	55 300	48 850	37 400	29 550	25 550								7
8	46 650	47 850	45 050	34 200	29 550	24 400	22 500							8
9	38 300	40 150	40 350	31 400	29 300	22 650	20 850	16 900	14 900	14 450				9
10	30 700	33 200	32 850	31 000	27 200	21 050	19 300	16 900	14 900	14 450	13 050	11 850		10
12		23 600	24 300	24 200	23 600	18 500	16 750	16 050	14 900	14 450	13 050	11 850		12
14		17 750	18 950	18 500	18 050	16 350	14 650	14 250	14 050	13 400	13 050	11 850		14
16			15 100	15 500	14 600	14 250	13 150	12 800	12 600	11 950	11 850	11 400		16
18			12 300	12 650	12 700	12 050	11 900	11 500	11 350	10 750	10 650	10 250		18
20				10 500	10 650	10 600	10 200	10 000	10 150	9 750	9 650	9 300		20
22				8 850	9 100	9 000	8 850	8 400	8 550	8 200	8 350	8 250		22
24					7 800	7 750	7 650	7 200	7 350	7 000	7 150	7 050		24
26					6 700	6 650	6 550	6 100	6 300	5 950	6 100	6 000		26
28						5 750	5 650	5 250	5 400	5 100	5 250	5 100		28
30						4 950	4 900	4 500	4 650	4 350	4 500	4 400		30
32						4 300	4 250	3 800	4 000	3 700	3 850	3 750		32
34							3 650	3 250	3 400	3 100	3 250	3 200		34
36							3 200	2 750	2 900	2 600	2 750	2 700		36
38								2 350	2 500	2 200	2 350	2 250		38
40								1 950	2 100	1 800	1 950	1 850		40
42										1 450	1 600	1 500		42
44											1 300	1 200		44
46												950		46

* Depicts multiple boom modes

** Special conditions or optional equipment required

This information is not for crane operation. Operator must refer to the in-cab information for crane operation. Rated lifting capacities shown on fully extended outriggers do not exceed 75% of the tipping loads and on tires do not exceed 65% of the tipping loads.

Metric Main Boom Lift Capacity Charts – 75% – Optional

19 505 kg Counterweight - Fully Extended Outriggers - 360° Rotation
 (All Capacities Are Listed In kilograms)

Radius (m)	Boom Length (m)												Radius (m)	
	12.61	16.8-16.9*	21.3-21.5*	25.9-26.27*	30.5	34.14-35.1*	38.01-39.6*	42.7	44.2	45.72	47.2	49.38		
2.5	**120 000													2.5
3	110 050	71 200	68 500											3
3.5	101 400	71 200	68 500											3.5
4	93 950	71 200	65 600											4
4.5	87 400	71 200	62 050	47 850										4.5
5	81 100	71 200	58 900	45 700										5
6	67 100	68 250	53 450	41 150	29 550	25 550								6
7	56 900	58 100	48 850	37 400	29 550	25 550								7
8	49 150	50 350	45 050	34 200	29 550	24 400	22 500							8
9	43 050	44 300	41 700	31 400	29 300	22 650	20 850	16 900	14 900	14 450				9
10	37 100	39 050	38 800	31 000	27 200	21 050	19 300	16 900	14 900	14 450	13 050	11 850		10
12		28 400	29 100	29 000	23 600	18 500	16 750	16 050	14 900	14 450	13 050	11 850		12
14		21 600	22 350	22 350	20 700	16 350	14 650	14 250	14 050	13 400	13 050	11 850		14
16			18 200	17 850	17 450	14 600	13 150	12 800	12 600	11 950	11 850	11 400		16
18			14 950	14 650	14 300	13 150	11 900	11 500	11 350	10 750	10 650	10 250		18
20				12 850	12 150	11 850	10 800	10 450	10 300	9 750	9 650	9 300		20
22				11 000	11 000	10 000	9 900	9 500	9 450	8 850	8 850	8 450		22
24					9 550	9 250	9 150	8 750	8 650	8 000	8 050	7 700		24
26					8 350	8 350	8 000	7 800	7 950	7 300	7 300	7 050		26
28						7 350	7 000	6 850	7 000	6 650	6 650	6 450		28
30						6 450	6 350	5 950	6 150	5 800	5 950	5 850		30
32						5 700	5 600	5 200	5 350	5 050	5 200	5 100		32
34							4 950	4 550	4 700	4 400	4 550	4 450		34
36							4 400	4 000	4 150	3 850	4 000	3 900		36
38								3 450	3 650	3 350	3 500	3 400		38
40								3 050	3 200	2 900	3 050	2 950		40
42										2 500	2 650	2 550		42
44											2 300	2 200		44
46												1 850		46

* Depicts multiple boom modes

** Special conditions or optional equipment required

This information is not for crane operation. Operator must refer to the in-cab information for crane operation. Rated lifting capacities shown on fully extended outriggers do not exceed 75% of the tipping loads and on tires do not exceed 65% of the tipping loads.

Metric Manual Offset Fly Attachment Lift Capacity Charts – 75% – Optional

13 154 kg Counterweight - Fully Extended Outriggers - 360° Rotation (All Capacities Are Listed In kilograms)											
Radius (m)	Main Boom + 3.0m Manual Offset Fly (2°, 15°, 30°, 45° Offsets)										Radius (m)
	Main Boom Length (m)										
	12.61	16.8	21.3	25.9	30.5	35.1	39.6	44.2	47.2	49.38	
3	23 500	23 500									3
3.5	21 550	23 500	22 050								3.5
4	21 300	23 500	22 050								4
4.5	21 050	21 250	22 050	22 050							4.5
5	20 850	21 050	22 050	22 050							5
6	20 500	20 750	20 550	20 000	19 150						6
7	20 300	20 450	20 300	19 800	19 150						7
8	20 200	20 250	20 100	19 650	18 650	17 400	13 100				8
9	20 200	20 150	19 950	19 500	17 950	17 400	13 100	11 600	10 150		9
10	20 200	20 050	19 650	19 400	16 700	17 250	13 100	11 600	10 150		10
12	20 200	20 050	17 200	17 150	14 750	15 250	13 100	11 600	10 150	9 050	12
14		18 700	15 350	15 350	13 050	13 550	12 150	11 600	10 150	9 050	14
16		14 800	13 800	13 750	11 700	12 100	10 850	11 400	10 150	9 050	16
18			12 500	12 400	10 500	10 900	9 700	10 350	9 750	9 050	18
20			10 550	10 650	9 550	9 900	8 750	9 400	8 800	8 400	20
22				9 000	8 700	8 850	7 950	8 350	7 950	7 700	22
24				7 750	7 800	7 600	7 350	7 150	6 950	6 850	24
26				6 650	6 700	6 550	6 400	6 050	5 900	5 800	26
28					5 850	5 650	5 500	5 200	5 000	4 900	28
30					5 050	4 900	4 750	4 450	4 250	4 150	30
32						4 250	4 100	3 800	3 600	3 500	32
34						3 650	3 550	3 250	3 050	2 950	34
36							3 050	2 750	2 550	2 450	36
38							2 600	2 300	2 150	2 050	38
40							2 250	1 950	1 750	1 650	40
42								1 600	1 450	1 300	42
44								1 300	1 150	1 000	44
46									850	750	46
48										500	48

This information is not for crane operation. Operator must refer to the in-cab information for crane operation. Rated lifting capacities shown on fully extended outriggers do not exceed 75% of the tipping loads and on tires do not exceed 65% of the tipping loads.

19 505 kg Counterweight - Fully Extended Outriggers - 360° Rotation
(All Capacities Are Listed In kilograms)

Radius (m)	Main Boom + 3.0m Manual Offset Fly (2°, 15°, 30°, 45° Offsets)										Radius (m)
	Main Boom Length (m)										
	12.61	16.8	21.3	25.9	30.5	35.1	39.6	44.2	47.2	49.38	
3	23 500	23 500									3
3.5	21 550	23 500	22 050								3.5
4	21 300	23 500	22 050								4
4.5	21 050	21 250	22 050	22 050							4.5
5	20 850	21 050	22 050	22 050							5
6	20 500	20 750	20 550	20 000	19 150						6
7	20 300	20 450	20 300	19 800	19 150						7
8	20 200	20 250	20 100	19 650	18 650	17 400	13 100				8
9	20 200	20 150	19 950	19 500	17 950	17 400	13 100	11 600	10 150		9
10	20 200	20 050	19 650	19 400	16 700	17 250	13 100	11 600	10 150		10
12	20 200	20 050	17 200	17 150	14 750	15 250	13 100	11 600	10 150	9 050	12
14		20 050	15 350	15 350	13 050	13 550	12 150	11 600	10 150	9 050	14
16		18 000	13 800	13 750	11 700	12 100	10 850	11 400	10 150	9 050	16
18			12 500	12 400	10 500	10 900	9 700	10 350	9 750	9 050	18
20			11 450	11 300	9 550	9 900	8 750	9 400	8 800	8 400	20
22				10 350	8 700	9 000	7 950	8 550	7 950	7 700	22
24				9 550	8 000	8 250	7 350	7 800	7 350	7 000	24
26				8 400	7 450	7 650	6 700	7 200	6 700	6 350	26
28					6 850	7 100	6 150	6 600	6 100	5 800	28
30					6 350	6 350	5 650	5 900	5 600	5 250	30
32						5 600	5 250	5 150	5 000	4 800	32
34						4 950	4 800	4 500	4 350	4 250	34
36							4 250	3 950	3 800	3 650	36
38							3 750	3 450	3 300	3 150	38
40							3 350	3 000	2 850	2 750	40
42								2 600	2 450	2 350	42
44								2 250	2 100	2 000	44
46									1 750	1 650	46
48										1 350	48

This information is not for crane operation. Operator must refer to the in-cab information for crane operation. Rated lifting capacities shown on fully extended outriggers do not exceed 75% of the tipping loads and on tires do not exceed 65% of the tipping loads.

13 154 kg Counterweight - Fully Extended Outriggers - 360° Rotation (All Capacities Are Listed In kilograms)									
Radius (m)	49.3 m Main Boom Length								Radius (m)
	9.4m Manual Offset Fly				16.8m Manual Offset Fly				
	2° Offset	15° Offset	30° Offset	45° Offset	2° Offset	15° Offset	30° Offset	45° Offset	
12	6 600				4 800				12
14	6 600	6 650			4 800				14
16	6 600	6 650			4 800				16
18	6 600	6 650	6 400	6 000	4 800	4 400			18
20	6 600	6 650	6 350	5 950	4 800	4 300			20
22	6 600	6 650	6 250	5 900	4 750	4 200	3 750		22
24	6 550	6 650	6 150	5 850	4 600	4 100	3 650		24
26	5 950	6 050	6 100	5 800	4 500	4 050	3 600	3 300	26
28	5 050	5 350	5 650	5 750	4 400	3 950	3 550	3 300	28
30	4 300	4 550	4 850	5 050	4 300	3 850	3 500	3 250	30
32	3 650	3 900	4 150	4 300	3 950	3 800	3 450	3 200	32
34	3 100	3 300	3 550	3 700	3 400	3 700	3 400	3 200	34
36	2 600	2 800	3 000	3 100	2 900	3 250	3 350	3 150	36
38	2 150	2 350	2 500	2 600	2 450	2 800	3 150	3 150	38
40	1 800	1 950	2 100	2 200	2 100	2 400	2 700	2 900	40
42	1 450	1 600	1 700	1 800	1 750	2 000	2 300	2 450	42
44	1 150	1 250	1 350	1 400	1 400	1 650	1 900	2 050	44
46	850	950	1 050		1 150	1 350	1 600	1 700	46
48	600	700	800		900	1 100	1 250	1 400	48
50	400	450	500		650	850	1 000	1 050	50
52					450	600	750	800	52
54						400	500		54

19 505 kg Counterweight - Fully Extended Outriggers - 360° Rotation (All Capacities Are Listed In kilograms)									
Radius (m)	49.3 m Main Boom Length								Radius (m)
	9.4m Manual Offset Fly				16.8m Manual Offset Fly				
	2° Offset	15° Offset	30° Offset	45° Offset	2° Offset	15° Offset	30° Offset	45° Offset	
12	6 600				4 800				12
14	6 600	6 650			4 800				14
16	6 600	6 650			4 800				16
18	6 600	6 650	6 400	6 000	4 800	4 400			18
20	6 600	6 650	6 350	5 950	4 800	4 300			20
22	6 600	6 650	6 250	5 900	4 750	4 200	3 750		22
24	6 550	6 650	6 150	5 850	4 600	4 100	3 650		24
26	5 950	6 050	6 100	5 800	4 500	4 050	3 600	3 300	26
28	5 450	5 550	5 650	5 750	4 400	3 950	3 550	3 300	28
30	4 950	5 050	5 150	5 250	4 300	3 850	3 500	3 250	30
32	4 550	4 650	4 750	4 800	4 200	3 800	3 450	3 200	32
34	4 150	4 250	4 350	4 400	3 800	3 700	3 400	3 200	34
36	3 800	3 900	3 950	4 050	3 500	3 600	3 350	3 150	36
38	3 300	3 500	3 650	3 700	3 200	3 300	3 300	3 150	38
40	2 850	3 000	3 150	3 250	2 900	3 050	3 150	3 150	40
42	2 450	2 600	2 750	2 800	2 650	2 750	2 850	2 950	42
44	2 100	2 250	2 350	2 400	2 400	2 550	2 650	2 700	44
46	1 800	1 900	2 000		2 050	2 300	2 400	2 450	46
48	1 500	1 600	1 650		1 750	1 950	2 150	2 250	48
50	1 250	1 300	1 350		1 500	1 700	1 850	1 900	50
52	1 000	1 050			1 250	1 400	1 550	1 600	52
54	750	800			1 000	1 150	1 250		54
56	600				800	950	1 000		56
58					600	700	750		58
60					450	500			60

This information is not for crane operation. Operator must refer to the in-cab information for crane operation. Rated lifting capacities shown on fully extended outriggers do not exceed 75% of the tipping loads and on tires do not exceed 65% of the tipping loads.

13 154 kg Counterweight - Fully Extended Outriggers - 360° Rotation (All Capacities Are Listed In kilograms)													
49.38 m Main Boom Length													
Radius (m)	22.3 m Manual Offset fly				27.7 m Manual Offset fly				33.2 m Manual Offset fly				Radius (m)
	2°	15°	30°	45°	2°	15°	30°	45°	2°	15°	30°	45°	
18	3 850				2 950								18
20	3 850				2 950				2 250				20
22	3 850	3 900			2 950				2 250				22
24	3 850	3 850			2 950	2 900			2 250				24
26	3 850	3 800	3 450		2 950	2 900			2 250	2 250			26
28	3 850	3 750	3 400		2 950	2 900	2 750		2 250	2 250			28
30	3 850	3 700	3 350	3 000	2 950	2 900	2 600		2 250	2 100			30
32	3 850	3 600	3 250	2 900	2 950	2 750	2 450	2 250	2 150	1 950	1 800		32
34	3 300	3 550	3 100	2 800	2 850	2 600	2 300	2 150	2 000	1 850	1 700	1 600	34
36	2 800	3 150	3 000	2 700	2 700	2 450	2 200	2 050	1 850	1 700	1 550	1 450	36
38	2 350	2 700	2 900	2 650	2 350	2 300	2 100	1 950	1 750	1 600	1 450	1 350	38
40	1 950	2 250	2 600	2 550	1 950	2 200	2 000	1 850	1 600	1 500	1 350	1 300	40
42	1 600	1 900	2 200	2 400	1 600	1 850	1 900	1 800	1 500	1 400	1 250	1 200	42
44	1 300	1 550	1 850	2 050	1 250	1 500	1 800	1 700	1 200	1 300	1 200	1 100	44
46	1 000	1 250	1 500	1 700	950	1 200	1 500	1 650	900	1 150	1 100	1 050	46
48	750	950	1 200	1 350	700	950	1 200	1 350	650	900	1 050	1 000	48
50	500	700	900	1 050	450	650	900	1 050	400	650	900	900	50
52		500	650	750		450	650	800		400	650	800	52
54			400	500			400	550			400	550	54

19 505 kg Counterweight - Fully Extended Outriggers - 360° Rotation (All Capacities Are Listed In kilograms)													
49.38 m Main Boom Length													
Radius (m)	22.3 m Manual Offset fly				27.7 m Manual Offset fly				33.2 m Manual Offset fly				Radius (m)
	2°	15°	30°	45°	2°	15°	30°	45°	2°	15°	30°	45°	
18	3 850				2 950								18
20	3 850				2 950				2 250				20
22	3 850	3 900			2 950				2 250				22
24	3 850	3 850			2 950	2 900			2 250				24
26	3 850	3 800	3 450		2 950	2 900			2 250	2 250			26
28	3 850	3 750	3 400		2 950	2 900	2 750		2 250	2 250			28
30	3 850	3 700	3 350	3 000	2 950	2 900	2 600		2 250	2 100			30
32	3 850	3 600	3 250	2 900	2 950	2 750	2 450	2 250	2 150	1 950	1 800		32
34	3 550	3 550	3 100	2 800	2 850	2 600	2 300	2 150	2 000	1 850	1 700	1 600	34
36	3 200	3 300	3 000	2 700	2 700	2 450	2 200	2 050	1 850	1 700	1 550	1 450	36
38	2 900	3 050	2 900	2 650	2 500	2 300	2 100	1 950	1 750	1 600	1 450	1 350	38
40	2 650	2 750	2 800	2 550	2 250	2 200	2 000	1 850	1 600	1 500	1 350	1 300	40
42	2 400	2 500	2 600	2 500	2 050	2 100	1 900	1 800	1 500	1 400	1 250	1 200	42
44	2 200	2 250	2 400	2 450	1 800	1 900	1 800	1 700	1 400	1 300	1 200	1 100	44
46	1 950	2 050	2 150	2 250	1 600	1 700	1 750	1 650	1 300	1 200	1 100	1 050	46
48	1 650	1 850	1 950	2 050	1 450	1 550	1 650	1 600	1 100	1 150	1 050	1 000	48
50	1 350	1 550	1 750	1 850	1 250	1 350	1 450	1 550	950	1 050	950	900	50
52	1 100	1 300	1 450	1 600	1 050	1 200	1 300	1 350	800	900	900	850	52
54	900	1 050	1 200	1 300	800	1 000	1 100	1 200	650	750	850	800	54
56	650	800	950	1 000	600	750	950	1 050	500	600	700	750	56
58	500	600	700	750	400	550	700	800			550	600	58
60		400	500				500	550					60

This information is not for crane operation. Operator must refer to the in-cab information for crane operation. Rated lifting capacities shown on fully extended outriggers do not exceed 75% of the tipping loads and on tires do not exceed 65% of the tipping loads.

Metric Hydraulic Offset Fly Attachment Lift Capacity Charts — 75% — Optional

13 154 kg Counterweight - Fully Extended Outriggers - 360° Rotation (All Capacities Are Listed In kilograms)											
Radius (m)	Main Boom + 3.0m Hydraulic Offset Fly (2° - 45° Offsets)										Radius (m)
	Main Boom Length (m)										
	12.61	16.8	21.3	25.9	30.5	35.1	39.6	44.2	47.2	49.38	
3	23 500	23 500									3
3.5	21 500	23 500	22 000								3.5
4	21 200	23 500	22 000								4
4.5	21 000	21 200	22 000	22 000							4.5
5	20 800	21 000	22 000	22 000							5
6	20 450	20 650	20 450	19 900	19 100						6
7	20 250	20 400	20 200	19 750	19 100						7
8	20 150	20 200	20 000	19 600	18 600	17 300	13 050				8
9	19 950	20 050	19 850	19 450	17 800	17 300	13 050	11 550	10 100		9
10	19 400	20 000	19 450	19 350	16 550	17 050	13 050	11 550	10 100		10
12	19 050	19 550	17 000	17 000	14 600	15 050	13 050	11 550	10 100	9 000	12
14		18 500	15 150	15 150	12 900	13 350	12 000	11 550	10 100	9 000	14
16		14 650	13 600	13 550	11 500	11 900	10 650	11 250	10 100	9 000	16
18			12 300	12 250	10 350	10 700	9 550	10 150	9 550	9 000	18
20			10 400	10 450	9 350	9 700	8 600	9 200	8 600	8 200	20
22				8 850	8 550	8 650	7 800	8 150	7 800	7 500	22
24				7 550	7 600	7 450	7 150	6 950	6 800	6 650	24
26				6 500	6 550	6 350	6 200	5 900	5 700	5 600	26
28					5 650	5 450	5 300	5 000	4 800	4 700	28
30					4 850	4 700	4 550	4 250	4 100	3 950	30
32						4 050	3 900	3 600	3 450	3 300	32
34						3 500	3 350	3 050	2 850	2 750	34
36							2 850	2 550	2 400	2 300	36
38							2 450	2 150	1 950	1 850	38
40							2 100	1 750	1 600	1 450	40
42								1 400	1 250	1 150	42
44								1 100	950	850	44
46									650	550	46

This information is not for crane operation. Operator must refer to the in-cab information for crane operation. Rated lifting capacities shown on fully extended outriggers do not exceed 75% of the tipping loads and on tires do not exceed 65% of the tipping loads.

19 505 kg Counterweight - Fully Extended Outriggers - 360° Rotation (All Capacities Are Listed In kilograms)											
Radius (m)	Main Boom + 3.0m Hydraulic Offset Fly (2° - 45° Offsets)										Radius (m)
	Main Boom Length (m)										
	12.61	16.8	21.3	25.9	30.5	35.1	39.6	44.2	47.2	49.38	
3	23 500	23 500									3
3.5	21 500	23 500	22 000								3.5
4	21 200	23 500	22 000								4
4.5	21 000	21 200	22 000	22 000							4.5
5	20 800	21 000	22 000	22 000							5
6	20 450	20 650	20 450	19 900	19 100						6
7	20 250	20 400	20 200	19 750	19 100						7
8	20 150	20 200	20 000	19 600	18 600	17 300	13 050				8
9	19 950	20 050	19 850	19 450	17 800	17 300	13 050	11 550	10 100		9
10	19 400	20 000	19 450	19 350	16 550	17 050	13 050	11 550	10 100		10
12	19 050	19 550	17 000	17 000	14 600	15 050	13 050	11 550	10 100	9 000	12
14		18 950	15 150	15 150	12 900	13 350	12 000	11 550	10 100	9 000	14
16		17 850	13 600	13 550	11 500	11 900	10 650	11 250	10 100	9 000	16
18			12 300	12 250	10 350	10 700	9 550	10 150	9 550	9 000	18
20			11 300	11 100	9 350	9 700	8 600	9 200	8 600	8 200	20
22				10 200	8 550	8 800	7 800	8 350	7 800	7 500	22
24				9 400	7 800	8 050	7 150	7 700	7 150	6 800	24
26				8 250	7 250	7 500	6 550	7 000	6 500	6 150	26
28					6 700	6 900	5 950	6 400	5 900	5 600	28
30					6 200	6 200	5 500	5 750	5 400	5 100	30
32						5 450	5 050	5 000	4 800	4 650	32
34						4 800	4 650	4 350	4 150	4 050	34
36							4 100	3 800	3 600	3 500	36
38							3 600	3 300	3 100	3 000	38
40							3 150	2 850	2 650	2 550	40
42								2 450	2 250	2 150	42
44								2 100	1 900	1 800	44
46									1 600	1 500	46
48										1 200	48

This information is not for crane operation. Operator must refer to the in-cab information for crane operation. Rated lifting capacities shown on fully extended outriggers do not exceed 75% of the tipping loads and on tires do not exceed 65% of the tipping loads.

13 154 kg Counterweight - Fully Extended Outriggers - 360° Rotation (All Capacities Are Listed In kilograms)							
Radius (m)	49.3 m Main Boom Length						Radius (m)
	9.4m Hydraulic Offset Fly			16.8m Hydraulic Offset Fly			
	2° - 15°	15° - 30°	30° - 45°	2° - 15°	15° - 30°	30° - 45°	
12	6 500	6 500					12
14	6 500	6 500		4 700			14
16	6 500	6 400	6 400	4 700			16
18	6 500	6 300	5 850	4 300	4 300		18
20	6 500	6 250	5 750	4 200	4 200		20
22	6 500	6 150	5 700	4 100	3 550	3 550	22
24	6 150	6 050	5 600	4 000	3 550	3 050	24
26	5 550	5 650	5 550	3 900	3 500	3 000	26
28	4 900	5 150	5 250	3 850	3 450	2 950	28
30	4 150	4 450	4 700	3 750	3 350	2 900	30
32	3 500	3 750	4 000	3 650	3 300	2 850	32
34	2 950	3 150	3 400	3 250	3 250	2 800	34
36	2 450	2 650	2 850	2 750	3 150	2 800	36
38	2 000	2 200	2 400	2 350	2 700	2 750	38
40	1 650	1 800	1 950	1 950	2 250	2 550	40
42	1 300	1 450	1 550	1 600	1 900	2 150	42
44	1 000	1 100	1 250	1 300	1 550	1 800	44
46	700	800	900	1 000	1 250	1 450	46
48	450	550	650	750	950	1 150	48
50				500	700	850	50
52					450	600	52

19 505 kg Counterweight - Fully Extended Outriggers - 360° Rotation (All Capacities Are Listed In kilograms)							
Radius (m)	49.3 m Main Boom Length						Radius (m)
	9.4m Hydraulic Offset Fly			16.8m Hydraulic Offset Fly			
	2° - 15°	15° - 30°	30° - 45°	2° - 15°	15° - 30°	30° - 45°	
12	6 500	6 500					12
14	6 500	6 500		4 700			14
16	6 500	6 400	6 400	4 700			16
18	6 500	6 300	5 850	4 300	4 300		18
20	6 500	6 250	5 750	4 200	4 200		20
22	6 500	6 150	5 700	4 100	3 550	3 550	22
24	6 150	6 050	5 600	4 000	3 550	3 050	24
26	5 550	5 650	5 550	3 900	3 500	3 000	26
28	5 050	5 150	5 250	3 850	3 450	2 950	28
30	4 550	4 650	4 750	3 750	3 350	2 900	30
32	4 150	4 250	4 350	3 650	3 300	2 850	32
34	3 750	3 850	3 950	3 450	3 250	2 800	34
36	3 400	3 500	3 550	3 100	3 200	2 800	36
38	3 100	3 150	3 250	2 800	2 900	2 750	38
40	2 700	2 850	2 950	2 550	2 650	2 750	40
42	2 300	2 450	2 600	2 300	2 400	2 500	42
44	1 950	2 100	2 200	2 050	2 150	2 250	44
46	1 650	1 750	1 850	1 850	1 900	2 000	46
48	1 350	1 450	1 500	1 650	1 700	1 800	48
50	1 050	1 150	1 200	1 350	1 500	1 600	50
52	850	900		1 100	1 300	1 400	52
54	600	650		900	1 050	1 150	54
56				650	800	850	56
58				500	600	600	58
60					400		60

This information is not for crane operation. Operator must refer to the in-cab information for crane operation. Rated lifting capacities shown on fully extended outriggers do not exceed 75% of the tipping loads and on tires do not exceed 65% of the tipping loads.

13 154 kg Counterweight - Fully Extended Outriggers - 360° Rotation
(All Capacities Are Listed In kilograms)

49.38 m Main Boom Length

Radius (m)	22.3 m Hydraulic Offset fly			27.7 m Hydraulic Offset fly			33.2 m Hydraulic Offset fly			Radius (m)
	2° - 15°	15° - 30°	30° - 45°	2° - 15°	15° - 30°	30° - 45°	2° - 15°	15° - 30°	30° - 45°	
18	3 750			2 850						18
20	3 750	3 750		2 850			2 200			20
22	3 750	3 750		2 850			2 200			22
24	3 750	3 400	3 400	2 850	2 850		2 200	2 200		24
26	3 700	3 350	3 350	2 850	2 850		2 050	2 050		26
28	3 600	3 200	2 800	2 700	2 350	2 350	1 900	1 900		28
30	3 550	3 050	2 650	2 500	2 200	2 000	1 700	1 550	1 550	30
32	3 400	2 900	2 550	2 350	2 050	1 900	1 550	1 400	1 250	32
34	3 150	2 750	2 450	2 200	1 950	1 750	1 400	1 250	1 150	34
36	2 650	2 650	2 400	2 050	1 800	1 650	1 300	1 150	1 050	36
38	2 250	2 550	2 300	1 950	1 700	1 550	1 150	1 000	950	38
40	1 850	2 150	2 200	1 800	1 600	1 500	1 050	900	800	40
42	1 500	1 750	2 050	1 450	1 500	1 400	950	800	750	42
44	1 150	1 400	1 700	1 100	1 400	1 300	850	700	650	44
46	900	1 100	1 350	800	1 050	1 250	750	650	550	46
48	600	850	1 050	550	800	1 050	500	550		48
50	400	550	800		550	800				50
52			550			500				52

19 505 kg Counterweight - Fully Extended Outriggers - 360° Rotation
(All Capacities Are Listed In kilograms)

49.38 m Main Boom Length

Radius (m)	22.3 m Hydraulic Offset fly			27.7 m Hydraulic Offset fly			33.2 m Hydraulic Offset fly			Radius (m)
	2° - 15°	15° - 30°	30° - 45°	2° - 15°	15° - 30°	30° - 45°	2° - 15°	15° - 30°	30° - 45°	
18	3 750			2 850						18
20	3 750	3 750		2 850			2 200			20
22	3 750	3 750		2 850			2 200			22
24	3 750	3 400	3 400	2 850	2 850		2 200	2 200		24
26	3 700	3 350	3 350	2 850	2 850		2 050	2 050		26
28	3 600	3 200	2 800	2 700	2 350	2 350	1 900	1 900		28
30	3 550	3 050	2 650	2 500	2 200	2 000	1 700	1 550	1 550	30
32	3 400	2 900	2 550	2 350	2 050	1 900	1 550	1 400	1 250	32
34	3 150	2 750	2 450	2 200	1 950	1 750	1 400	1 250	1 150	34
36	2 800	2 650	2 400	2 050	1 800	1 650	1 300	1 150	1 050	36
38	2 500	2 550	2 300	1 950	1 700	1 550	1 150	1 000	950	38
40	2 250	2 350	2 200	1 800	1 600	1 500	1 050	900	800	40
42	2 000	2 100	2 150	1 600	1 500	1 400	950	800	750	42
44	1 750	1 850	2 000	1 400	1 450	1 300	850	700	650	44
46	1 550	1 650	1 750	1 200	1 300	1 250	750	650	550	46
48	1 350	1 450	1 550	1 000	1 100	1 200	650	550		48
50	1 150	1 250	1 350	850	950	1 050				50
52	950	1 100	1 150	650	750	850				52
54	750	900	1 000	500	600	700				54
56	550	650	800			500				56
58		450	600							58

This information is not for crane operation. Operator must refer to the in-cab information for crane operation. Rated lifting capacities shown on fully extended outriggers do not exceed 75% of the tipping loads and on tires do not exceed 65% of the tipping loads.

Metric On Tires Lift Capacity Charts – 75% – Standard

11 794 kg Counterweight - On Tires - Stationary - Boom Centered Over Rear Between Tire Tracks (All Capacities Are Listed In kilograms)						
Radius (m)	Boom Length (m)					Radius (m)
	12.61	16.8	21.3	25.9	30.5	
3	41 700					3
3.5	33 650					3.5
4	30 550					4
4.5	27 950	23 100				4.5
5	25 700	23 100				5
6	22 050	23 100	14 900			6
7	19 100	20 550	14 900			7
8	15 050	16 950	14 900	11 850		8
9	11 950	13 800	14 900	11 850	9 750	9
10	9 550	11 400	12 500	11 850	9 750	10
12		8 050	9 100	9 450	9 650	12
14		5 850	6 900	7 250	7 450	14
16			5 250	5 600	5 850	16
18			4 050	4 400	4 600	18
20				3 450	3 650	20
22				2 700	2 900	22
24					2 250	24
26					1 750	26

11 794 kg Counterweight - On Tires - Pick & Carry (Creep) - Boom Centered Over Rear (All Capacities Are Listed In kilograms)						
Radius (m)	Boom Length (m)					Radius (m)
	12.61	16.8	21.3	25.9		
3	40 250					3
3.5	36 700					3.5
4	33 300					4
4.5	30 350	21 950				4.5
5	27 800	21 950				5
6	20 100	21 950	12 150			6
7	15 200	17 050	12 150			7
8	11 750	13 600	12 150	9 750		8
9	9 250	11 000	12 100	9 750		9
10	7 300	9 050	10 150	9 750		10
12		6 300	7 350	7 700		12
14		4 450	5 450	5 750		14
16			4 050	4 400		16
18			3 000	3 350		18
20				2 500		20
22				1 850		22

This information is not for crane operation. Operator must refer to the in-cab information for crane operation. Rated lifting capacities shown on fully extended outriggers do not exceed 75% of the tipping loads and on tires do not exceed 65% of the tipping loads.

Metric Main Boom Lift Capacity Charts – 85% – Standard

13 154 kg Counterweight - Fully Extended Outriggers - 360° Rotation
(All Capacities Are Listed In kilograms)

Radius (m)	Boom Length (m)											Radius (m)		
	12.61	16.8-16.9*	21.3-21.5*	25.9-26.27*	30.5	34.14-35.1*	38.01-39.6*	42.7	44.2	45.72	47.2		49.38	
2.5	120 000													2.5
3	110 000	71 200	68 500											3
3.5	101 350	71 200	68 500											3.5
4	93 900	71 200	65 600											4
4.5	85 900	71 200	62 050	47 850										4.5
5	77 200	71 200	58 900	45 700										5
6	63 800	64 950	53 450	41 100	29 550	25 550								6
7	54 050	55 300	48 850	37 400	29 550	25 550								7
8	46 650	47 850	45 050	34 150	29 550	24 400	22 500							8
9	40 800	42 050	41 700	31 400	29 300	22 650	20 800	16 900	14 900	14 450				9
10		35 150	35 350	31 000	27 200	21 050	19 300	16 900	14 900	14 450	13 000	11 800		10
12		25 550	26 200	26 150	23 600	18 500	16 750	16 050	14 900	14 450	13 000	11 800		12
14		19 400	20 250	20 100	19 650	16 350	14 650	14 250	14 050	13 400	13 000	11 800		14
16			16 450	16 000	15 750	14 600	13 150	12 800	12 600	11 950	11 850	11 400		16
18			13 500	13 850	13 100	12 700	11 900	11 500	11 350	10 750	10 650	10 250		18
20				11 600	11 650	10 950	10 800	10 450	10 300	9 750	9 650	9 300		20
22				9 850	9 900	9 900	9 550	9 350	9 450	8 850	8 850	8 450		22
24					8 650	8 550	8 150	7 950	8 100	7 800	7 950	7 700		24
26					7 550	7 450	7 350	6 900	7 050	6 750	6 900	6 800		26
28						6 500	6 400	6 000	6 150	5 850	5 950	5 850		28
30						5 650	5 600	5 200	5 350	5 050	5 200	5 100		30
32						5 000	4 900	4 500	4 650	4 350	4 500	4 400		32
34							4 300	3 900	4 050	3 750	3 900	3 800		34
36							3 800	3 400	3 550	3 250	3 400	3 300		36
38								2 900	3 050	2 800	2 900	2 850		38
40								2 500	2 650	2 400	2 500	2 400		40
42										2 000	2 150	2 050		42
44											1 850	1 750		44
46												1 450		46

* Depicts multiple boom modes

** Special conditions or optional equipment required

This information is not for crane operation. Operator must refer to the in-cab information for crane operation. Rated lifting capacities shown on fully extended outriggers do not exceed 85% of the tipping loads and on tires do not exceed 75% of the tipping loads.

Metric Main Boom Lift Capacity Charts – 85% – Optional

19 505 kg Counterweight - Fully Extended Outriggers - 360° Rotation
(All Capacities Are Listed In kilograms)

Radius (m)	Boom Length (m)											Radius (m)		
	12.61	16.8-16.9*	21.3-21.5*	25.9-26.27*	30.5	34.14-35.1*	38.01-39.6*	42.7	44.2	45.72	47.2		49.38	
2.5	120 000													2.5
3	110 000	71 200	68 500											3
3.5	101 350	71 200	68 500											3.5
4	93 900	71 200	65 600											4
4.5	87 300	71 200	62 050	47 850										4.5
5	81 100	71 200	58 900	45 700										5
6	67 100	68 250	53 450	41 100	29 550	25 550								6
7	56 900	58 100	48 850	37 400	29 550	25 550								7
8	49 150	50 350	45 050	34 150	29 550	24 400	22 500							8
9	43 050	44 300	41 700	31 400	29 300	22 650	20 800	16 900	14 900	14 450				9
10		39 400	38 800	31 000	27 200	21 050	19 300	16 900	14 900	14 450	13 000	11 800		10
12		30 700	31 150	29 400	23 600	18 500	16 750	16 050	14 900	14 450	13 000	11 800		12
14		23 500	24 200	24 150	20 700	16 350	14 650	14 250	14 050	13 400	13 000	11 800		14
16			19 400	19 400	18 450	14 600	13 150	12 800	12 600	11 950	11 850	11 400		16
18			16 300	16 000	15 650	13 150	11 900	11 500	11 350	10 750	10 650	10 250		18
20				13 450	13 100	11 900	10 800	10 450	10 300	9 750	9 650	9 300		20
22				11 800	11 350	10 850	9 900	9 500	9 450	8 850	8 850	8 450		22
24					10 150	9 500	9 150	8 750	8 650	8 000	8 050	7 700		24
26					9 200	8 550	8 450	8 050	7 950	7 250	7 300	7 050		26
28						7 900	7 800	7 400	7 300	6 600	6 650	6 400		28
30						7 250	6 950	6 750	6 750	6 050	6 100	5 850		30
32						6 450	6 150	5 950	6 150	5 500	5 550	5 350		32
34							5 500	5 250	5 450	5 050	5 100	4 850		34
36							5 050	4 650	4 800	4 500	4 650	4 450		36
38								4 150	4 300	4 000	4 150	4 050		38
40								3 650	3 800	3 500	3 650	3 550		40
42										3 100	3 250	3 150		42
44											2 850	2 750		44
46												2 450		46

* Depicts multiple boom modes

** Special conditions or optional equipment required

This information is not for crane operation. Operator must refer to the in-cab information for crane operation. Rated lifting capacities shown on fully extended outriggers do not exceed 85% of the tipping loads and on tires do not exceed 75% of the tipping loads.

Metric Manual Offset Fly Attachment Lift Capacity Charts – 85% – Optional

13 154 kg Counterweight - Fully Extended Outriggers - 360° Rotation (All Capacities Are Listed In kilograms)											
Radius (m)	Main Boom + 3.0m Manual Offset Fly (2°, 15°, 30°, 45° Offsets)										Radius (m)
	Main Boom Length (m)										
	12.61	16.8	21.3	25.9	30.5	35.1	39.6	44.2	47.2	49.38	
3	23 500	23 500									3
3.5	21 550	23 500	22 050								3.5
4	21 300	23 500	22 050								4
4.5	21 050	21 250	22 050	22 050							4.5
5	20 850	21 050	22 050	22 050							5
6	20 500	20 750	20 550	20 000	19 150						6
7	20 300	20 450	20 300	19 800	19 150						7
8	20 200	20 250	20 100	19 650	18 650	17 400	13 100				8
9	20 200	20 150	19 950	19 500	17 950	17 400	13 100	11 600	10 150		9
10	20 200	20 050	19 650	19 400	16 700	17 250	13 100	11 600	10 150		10
12	20 200	20 050	17 200	17 150	14 750	15 250	13 100	11 600	10 150	9 050	12
14		20 050	15 350	15 350	13 050	13 550	12 150	11 600	10 150	9 050	14
16		16 150	13 800	13 750	11 700	12 100	10 850	11 400	10 150	9 050	16
18			12 500	12 400	10 500	10 900	9 700	10 350	9 750	9 050	18
20			11 450	11 300	9 550	9 900	8 750	9 400	8 800	8 400	20
22				9 950	8 700	9 000	7 950	8 550	7 950	7 700	22
24				8 550	8 000	8 250	7 350	7 800	7 350	7 000	24
26				7 450	7 450	7 350	6 700	6 900	6 700	6 350	26
28					6 550	6 400	6 150	5 950	5 750	5 650	28
30					5 750	5 600	5 450	5 150	4 950	4 850	30
32						4 900	4 750	4 450	4 300	4 150	32
34						4 300	4 150	3 850	3 700	3 600	34
36							3 650	3 350	3 200	3 050	36
38							3 200	2 900	2 700	2 600	38
40							2 800	2 500	2 300	2 200	40
42								2 150	1 950	1 850	42
44								1 600	1 650	1 550	44
46									1 350	1 250	46
48										950	48

This information is not for crane operation. Operator must refer to the in-cab information for crane operation. Rated lifting capacities shown on fully extended outriggers do not exceed 85% of the tipping loads and on tires do not exceed 75% of the tipping loads.

19 505 kg Counterweight - Fully Extended Outriggers - 360° Rotation (All Capacities Are Listed In kilograms)											
Radius (m)	Main Boom + 3.0m Manual Offset Fly (2°, 15°, 30°, 45° Offsets)										Radius (m)
	Main Boom Length (m)										
	12.61	16.8	21.3	25.9	30.5	35.1	39.6	44.2	47.2	49.38	
3	23 500	23 500									3
3.5	21 550	23 500	22 050								3.5
4	21 300	23 500	22 050								4
4.5	21 050	21 250	22 050	22 050							4.5
5	20 850	21 050	22 050	22 050							5
6	20 500	20 750	20 550	20 000	19 150						6
7	20 300	20 450	20 300	19 800	19 150						7
8	20 200	20 250	20 100	19 650	18 650	17 400	13 100				8
9	20 200	20 150	19 950	19 500	17 950	17 400	13 100	11 600	10 150		9
10	20 200	20 050	19 650	19 400	16 700	17 250	13 100	11 600	10 150		10
12	20 200	20 050	17 200	17 150	14 750	15 250	13 100	11 600	10 150	9 050	12
14		20 050	15 350	15 350	13 050	13 550	12 150	11 600	10 150	9 050	14
16		18 950	13 800	13 750	11 700	12 100	10 850	11 400	10 150	9 050	16
18			12 500	12 400	10 500	10 900	9 700	10 350	9 750	9 050	18
20			11 450	11 300	9 550	9 900	8 750	9 400	8 800	8 400	20
22				10 350	8 700	9 000	7 950	8 550	7 950	7 700	22
24				9 550	8 000	8 250	7 350	7 800	7 350	7 000	24
26				8 850	7 450	7 650	6 700	7 200	6 700	6 350	26
28					6 850	7 100	6 150	6 600	6 100	5 800	28
30					6 350	6 550	5 650	6 100	5 600	5 250	30
32						6 100	5 250	5 600	5 100	4 800	32
34						5 650	4 850	5 150	4 600	4 400	34
36							4 450	4 650	4 200	4 000	36
38							4 150	4 100	3 850	3 600	38
40							3 900	3 650	3 450	3 300	40
42								3 200	3 050	2 950	42
44								1 600	2 650	2 550	44
46									2 300	2 200	46
48										1 900	48

This information is not for crane operation. Operator must refer to the in-cab information for crane operation. Rated lifting capacities shown on fully extended outriggers do not exceed 85% of the tipping loads and on tires do not exceed 75% of the tipping loads.

13 154 kg Counterweight - Fully Extended Outriggers - 360° Rotation
(All Capacities Are Listed In kilograms)

Radius (m)	49.3 m Main Boom Length								Radius (m)
	9.4m Manual Offset Fly				16.8m Manual Offset Fly				
	2° Offset	15° Offset	30° Offset	45° Offset	2° Offset	15° Offset	30° Offset	45° Offset	
12	6 600				4 800				12
14	6 600	6 650			4 800				14
16	6 600	6 650			4 800				16
18	6 600	6 650	6 400	6 000	4 800	4 400			18
20	6 600	6 650	6 350	5 950	4 800	4 300			20
22	6 600	6 650	6 250	5 900	4 750	4 200	3 750		22
24	6 550	6 650	6 150	5 850	4 600	4 100	3 650		24
26	5 950	6 050	6 100	5 800	4 500	4 000	3 600	3 300	26
28	5 450	5 550	5 650	5 750	4 400	3 950	3 550	3 300	28
30	4 950	5 050	5 150	5 250	4 300	3 850	3 500	3 250	30
32	4 300	4 550	4 750	4 800	4 200	3 800	3 400	3 200	32
34	3 750	3 950	4 150	4 300	3 800	3 700	3 350	3 200	34
36	3 200	3 400	3 600	3 700	3 500	3 600	3 350	3 150	36
38	2 750	2 950	3 100	3 200	3 050	3 300	3 300	3 150	38
40	2 350	2 500	2 650	2 750	2 650	2 950	3 150	3 100	40
42	2 000	2 100	2 250	2 300	2 250	2 550	2 800	2 950	42
44	1 650	1 800	1 900	1 950	1 950	2 200	2 400	2 550	44
46	1 350	1 500	1 550		1 650	1 850	2 050	2 200	46
48	1 100	1 200	1 250		1 350	1 550	1 750	1 850	48
50	850	950	1 000		1 100	1 300	1 450	1 550	50
52	650	700			900	1 050	1 200	1 250	52
54		500			700	850	950		54
56					500	600	700		56
58							500		58

19 505 kg Counterweight - Fully Extended Outriggers - 360° Rotation
(All Capacities Are Listed In kilograms)

Radius (m)	49.3 m Main Boom Length								Radius (m)
	9.4m Manual Offset Fly				16.8m Manual Offset Fly				
	2° Offset	15° Offset	30° Offset	45° Offset	2° Offset	15° Offset	30° Offset	45° Offset	
12	6 600				4 800				12
14	6 600	6 650			4 800				14
16	6 600	6 650			4 800				16
18	6 600	6 650	6 400	6 000	4 800	4 400			18
20	6 600	6 650	6 350	5 950	4 800	4 300			20
22	6 600	6 650	6 250	5 900	4 750	4 200	3 750		22
24	6 550	6 650	6 150	5 850	4 600	4 100	3 650		24
26	5 950	6 050	6 100	5 800	4 500	4 000	3 600	3 300	26
28	5 450	5 550	5 650	5 750	4 400	3 950	3 550	3 300	28
30	4 950	5 050	5 150	5 250	4 300	3 850	3 500	3 250	30
32	4 550	4 650	4 750	4 800	4 200	3 800	3 400	3 200	32
34	4 150	4 250	4 350	4 400	3 800	3 700	3 350	3 200	34
36	3 800	3 900	3 950	4 050	3 500	3 600	3 350	3 150	36
38	3 500	3 550	3 650	3 700	3 200	3 300	3 300	3 150	38
40	3 200	3 300	3 350	3 400	2 900	3 000	3 150	3 100	40
42	2 950	3 000	3 050	3 100	2 650	2 750	2 850	2 950	42
44	2 700	2 750	2 800	2 850	2 450	2 550	2 650	2 700	44
46	2 350	2 450	2 550		2 250	2 300	2 400	2 450	46
48	2 050	2 150	2 200		2 050	2 100	2 200	2 250	48
50	1 750	1 850	1 900		1 850	1 900	2 000	2 050	50
52	1 500	1 550			1 700	1 750	1 800	1 850	52
54	1 250	1 300			1 500	1 600	1 650		54
56					1 300	1 400	1 500		56
58					1 100	1 200	1 250		58
60					900	1 000			60

This information is not for crane operation. Operator must refer to the in-cab information for crane operation. Rated lifting capacities shown on fully extended outriggers do not exceed 85% of the tipping loads and on tires do not exceed 75% of the tipping loads.

13 154 kg Counterweight - Fully Extended Outriggers - 360° Rotation (All Capacities Are Listed In kilograms)													
49.38 m Main Boom Length													
Radius (m)	22.3 m Manual Offset fly				27.7 m Manual Offset fly				33.2 m Manual Offset fly				Radius (m)
	2°	15°	30°	45°	2°	15°	30°	45°	2°	15°	30°	45°	
18	3 850				2 950								18
20	3 850				2 950				2 250				20
22	3 850	3 900			2 950				2 250				22
24	3 850	3 850			2 950	2 900			2 000				24
26	3 850	3 800	3 450		2 950	2 900			2 000	2 250			26
28	3 850	3 750	3 400		2 950	2 900	2 750		2 000	2 250			28
30	3 850	3 700	3 350	3 000	2 950	2 900	2 600		2 000	2 100			30
32	3 850	3 600	3 250	2 900	2 950	2 750	2 450	2 250	2 000	1 950	1 800		32
34	3 550	3 550	3 100	2 800	2 850	2 600	2 300	2 150	2 000	1 850	1 700	1 600	34
36	3 200	3 300	3 000	2 700	2 700	2 450	2 200	2 050	1 850	1 700	1 550	1 450	36
38	2 900	3 050	2 900	2 650	2 500	2 300	2 100	1 950	1 750	1 600	1 450	1 350	38
40	2 500	2 750	2 800	2 550	2 250	2 200	2 000	1 850	1 600	1 500	1 350	1 300	40
42	2 150	2 450	2 600	2 500	2 050	2 100	1 900	1 800	1 500	1 400	1 250	1 200	42
44	1 800	2 100	2 350	2 450	1 800	1 900	1 800	1 700	1 400	1 300	1 200	1 100	44
46	1 500	1 750	2 000	2 150	1 450	1 700	1 750	1 650	1 300	1 200	1 100	1 050	46
48	1 250	1 450	1 700	1 850	1 200	1 450	1 650	1 600	1 100	1 150	1 050	1 000	48
50	1 000	1 200	1 400	1 500	950	1 200	1 400	1 550	900	1 050	950	900	50
52	750	950	1 100	1 200	700	900	1 150	1 250	650	900	900	850	52
54	550	700	850	950	500	700	900	1 000		650	850	800	54
56		500	650	700		500	650	750			650	750	56
58							500					500	58

19 505 kg Counterweight - Fully Extended Outriggers - 360° Rotation (All Capacities Are Listed In kilograms)													
49.38 m Main Boom Length													
Radius (m)	22.3 m Manual Offset fly				27.7 m Manual Offset fly				33.2 m Manual Offset fly				Radius (m)
	2°	15°	30°	45°	2°	15°	30°	45°	2°	15°	30°	45°	
18	3 850				2 950								18
20	3 850				2 950				2 250				20
22	3 850	3 900			2 950				2 250				22
24	3 850	3 850			2 950	2 900			2 000				24
26	3 850	3 800	3 450		2 950	2 900			2 000	2 250			26
28	3 850	3 750	3 400		2 950	2 900	2 750		2 000	2 250			28
30	3 850	3 700	3 350	3 000	2 950	2 900	2 600		2 000	2 100			30
32	3 850	3 600	3 250	2 900	2 950	2 750	2 450	2 250	2 000	1 950	1 800		32
34	3 550	3 550	3 100	2 800	2 850	2 600	2 300	2 150	2 000	1 850	1 700	1 600	34
36	3 200	3 300	3 000	2 700	2 700	2 450	2 200	2 050	1 850	1 700	1 550	1 450	36
38	2 900	3 050	2 900	2 650	2 500	2 300	2 100	1 950	1 750	1 600	1 450	1 350	38
40	2 650	2 750	2 800	2 550	2 250	2 200	2 000	1 850	1 600	1 500	1 350	1 300	40
42	2 400	2 500	2 600	2 500	2 050	2 100	1 900	1 800	1 500	1 400	1 250	1 200	42
44	2 200	2 250	2 400	2 450	1 800	1 900	1 800	1 700	1 400	1 300	1 200	1 100	44
46	1 950	2 050	2 150	2 250	1 600	1 700	1 750	1 650	1 300	1 200	1 100	1 050	46
48	1 750	1 850	1 950	2 050	1 450	1 550	1 650	1 600	1 100	1 150	1 050	1 000	48
50	1 600	1 650	1 750	1 850	1 250	1 350	1 450	1 550	950	1 050	950	900	50
52	1 400	1 500	1 600	1 650	1 100	1 200	1 300	1 350	800	900	900	850	52
54	1 250	1 350	1 400	1 450	950	1 050	1 100	1 200	650	750	850	800	54
56	1 100	1 150	1 250	1 300	800	900	950	1 050	500	600	700	750	56
58	950	1 050	1 100	1 100	650	750	800	850			550	600	58
60	750	850	950		550	600	700	700					60
62	550	650	750			500	550	600					62
64		500	500										64

This information is not for crane operation. Operator must refer to the in-cab information for crane operation. Rated lifting capacities shown on fully extended outriggers do not exceed 85% of the tipping loads and on tires do not exceed 75% of the tipping loads.

Metric Hydraulic Offset Fly Attachment Lift Capacity Charts — 85% — Optional

13 154 kg Counterweight - Fully Extended Outriggers - 360° Rotation (All Capacities Are Listed In kilograms)											
Radius (m)	Main Boom + 3.0m Hydraulic Offset Fly (2° - 45° Offsets)										Radius (m)
	Main Boom Length (m)										
	12.61	16.8	21.3	25.9	30.5	35.1	39.6	44.2	47.2	49.38	
3	23 500	23 500									3
3.5	21 500	23 500	22 000								3.5
4	21 200	23 500	22 000								4
4.5	21 000	21 200	22 000	22 000							4.5
5	20 800	21 000	22 000	22 000							5
6	20 450	20 650	20 450	19 900	19 100						6
7	20 200	20 400	20 200	19 750	19 100						7
8	20 150	20 200	20 000	19 550	18 600	17 300	13 050				8
9	19 950	20 050	19 850	19 450	17 800	17 300	13 050	11 550	10 100		9
10	19 400	20 000	19 450	19 350	16 550	17 050	13 050	11 550	10 100		10
12	19 050	19 550	17 000	17 000	14 600	15 050	13 050	11 550	10 100	9 000	12
14		18 950	15 150	15 150	12 900	13 350	11 950	11 550	10 100	9 000	14
16		16 000	13 600	13 550	11 500	11 900	10 650	11 250	10 100	9 000	16
18			12 300	12 250	10 350	10 700	9 550	10 150	9 550	9 000	18
20			11 300	11 100	9 350	9 700	8 600	9 200	8 600	8 200	20
22				9 800	8 550	8 800	7 800	8 350	7 800	7 500	22
24				8 400	7 800	8 050	7 150	7 700	7 150	6 800	24
26				7 300	7 250	7 150	6 550	6 700	6 500	6 150	26
28					6 400	6 200	5 950	5 750	5 600	5 500	28
30					5 550	5 400	5 250	4 950	4 800	4 700	30
32						4 750	4 600	4 300	4 100	4 000	32
34						4 100	4 000	3 700	3 500	3 400	34
36							3 450	3 150	3 000	2 900	36
38							3 000	2 700	2 550	2 450	38
40							2 650	2 300	2 150	2 050	40
42								1 950	1 800	1 700	42
44								1 400	1 450	1 350	44
46									1 150	1 050	46
48										800	48

This information is not for crane operation. Operator must refer to the in-cab information for crane operation. Rated lifting capacities shown on fully extended outriggers do not exceed 85% of the tipping loads and on tires do not exceed 75% of the tipping loads.

19 505 kg Counterweight - Fully Extended Outriggers - 360° Rotation (All Capacities Are Listed In kilograms)											
Radius (m)	Main Boom + 3.0m Hydraulic Offset Fly (2° - 45° Offsets)										Radius (m)
	Main Boom Length (m)										
	12.61	16.8	21.3	25.9	30.5	35.1	39.6	44.2	47.2	49.38	
3	23 500	23 500									3
3.5	21 500	23 500	22 000								3.5
4	21 200	23 500	22 000								4
4.5	21 000	21 200	22 000	22 000							4.5
5	20 800	21 000	22 000	22 000							5
6	20 450	20 650	20 450	19 900	19 100						6
7	20 200	20 400	20 200	19 750	19 100						7
8	20 150	20 200	20 000	19 550	18 600	17 300	13 050				8
9	19 950	20 050	19 850	19 450	17 800	17 300	13 050	11 550	10 100		9
10	19 400	20 000	19 450	19 350	16 550	17 050	13 050	11 550	10 100		10
12	19 050	19 550	17 000	17 000	14 600	15 050	13 050	11 550	10 100	9 000	12
14		18 950	15 150	15 150	12 900	13 350	11 950	11 550	10 100	9 000	14
16		18 800	13 600	13 550	11 500	11 900	10 650	11 250	10 100	9 000	16
18			12 300	12 250	10 350	10 700	9 550	10 150	9 550	9 000	18
20			11 300	11 100	9 350	9 700	8 600	9 200	8 600	8 200	20
22				10 200	8 550	8 800	7 800	8 350	7 800	7 500	22
24				9 400	7 800	8 050	7 150	7 700	7 150	6 800	24
26				8 700	7 250	7 500	6 550	7 000	6 500	6 150	26
28					6 700	6 900	5 950	6 400	5 900	5 600	28
30					6 200	6 350	5 500	5 900	5 400	5 100	30
32						5 900	5 050	5 400	4 900	4 650	32
34						5 500	4 650	5 000	4 400	4 200	34
36							4 300	4 450	4 000	3 800	36
38							3 950	3 950	3 650	3 400	38
40							3 700	3 450	3 300	3 100	40
42								3 050	2 850	2 750	42
44								1 400	2 500	2 400	44
46									2 150	2 050	46
48										1 750	48

This information is not for crane operation. Operator must refer to the in-cab information for crane operation. Rated lifting capacities shown on fully extended outriggers do not exceed 85% of the tipping loads and on tires do not exceed 75% of the tipping loads.

13 154 kg Counterweight - Fully Extended Outriggers - 360° Rotation
(All Capacities Are Listed In kilograms)

Radius (m)	49.3 m Main Boom Length						Radius (m)
	9.4m Hydraulic Offset Fly			16.8m Hydraulic Offset Fly			
	2° - 15°	15° - 30°	30° - 45°	2° - 15°	15° - 30°	30° - 45°	
12	6 500	6 500					12
14	6 500	6 500		4 700			14
16	6 500	6 400	6 400	4 700			16
18	6 500	6 300	5 850	4 300	4 300		18
20	6 500	6 200	5 750	4 200	4 200		20
22	6 500	6 150	5 700	4 100	3 550	3 550	22
24	6 150	6 050	5 600	4 000	3 550	3 050	24
26	5 550	5 650	5 550	3 900	3 500	3 000	26
28	5 050	5 150	5 250	3 800	3 400	2 950	28
30	4 550	4 650	4 750	3 750	3 350	2 900	30
32	4 150	4 250	4 350	3 650	3 300	2 850	32
34	3 600	3 800	3 950	3 450	3 250	2 800	34
36	3 050	3 250	3 450	3 100	3 200	2 800	36
38	2 600	2 800	2 950	2 800	2 900	2 750	38
40	2 200	2 350	2 500	2 500	2 650	2 750	40
42	1 850	2 000	2 100	2 150	2 400	2 500	42
44	1 500	1 650	1 750	1 800	2 050	2 250	44
46	1 200	1 350	1 400	1 500	1 750	1 950	46
48	950	1 050	1 100	1 250	1 450	1 650	48
50	700	800	850	1 000	1 200	1 350	50
52	500	550	550	750	950	1 050	52
54				550	700	800	54
56					500	550	56

19 505 kg Counterweight - Fully Extended Outriggers - 360° Rotation
(All Capacities Are Listed In kilograms)

Radius (m)	49.3 m Main Boom Length						Radius (m)
	9.4m Hydraulic Offset Fly			16.8m Hydraulic Offset Fly			
	2° - 15°	15° - 30°	30° - 45°	2° - 15°	15° - 30°	30° - 45°	
12	6 500	6 500					12
14	6 500	6 500		4 700			14
16	6 500	6 400	6 400	4 700			16
18	6 500	6 300	5 850	4 300	4 300		18
20	6 500	6 200	5 750	4 200	4 200		20
22	6 500	6 150	5 700	4 100	3 550	3 550	22
24	6 150	6 050	5 600	4 000	3 550	3 050	24
26	5 550	5 650	5 550	3 900	3 500	3 000	26
28	5 050	5 150	5 250	3 800	3 400	2 950	28
30	4 550	4 650	4 750	3 750	3 350	2 900	30
32	4 150	4 250	4 350	3 650	3 300	2 850	32
34	3 750	3 850	3 950	3 450	3 250	2 800	34
36	3 400	3 500	3 550	3 100	3 200	2 800	36
38	3 100	3 150	3 250	2 800	2 900	2 750	38
40	2 800	2 850	2 950	2 550	2 650	2 750	40
42	2 500	2 600	2 650	2 300	2 400	2 500	42
44	2 250	2 350	2 400	2 050	2 150	2 250	44
46	2 000	2 100	2 150	1 850	1 900	2 000	46
48	1 800	1 850	1 900	1 650	1 700	1 800	48
50	1 600	1 650	1 700	1 450	1 500	1 600	50
52	1 350	1 400	1 400	1 300	1 350	1 400	52
54	1 100			1 100	1 200	1 250	54
56				950	1 050	1 100	56
58				800	850	900	58
60				700	700		60

This information is not for crane operation. Operator must refer to the in-cab information for crane operation. Rated lifting capacities shown on fully extended outriggers do not exceed 85% of the tipping loads and on tires do not exceed 75% of the tipping loads.

13 154 kg Counterweight - Fully Extended Outriggers - 360° Rotation
(All Capacities Are Listed In kilograms)

49.38 m Main Boom Length

Radius (m)	22.3 m Hydraulic Offset fly			27.7 m Hydraulic Offset fly			33.2 m Hydraulic Offset fly			Radius (m)
	2° - 15°	15° - 30°	30° - 45°	2° - 15°	15° - 30°	30° - 45°	2° - 15°	15° - 30°	30° - 45°	
18	3 750			2 850						18
20	3 750	3 750		2 850			2 200			20
22	3 750	3 750		2 850			2 200			22
24	3 750	3 400	3 400	2 850	2 850		2 200	2 200		24
26	3 700	3 350	3 350	2 850	2 850		2 050	2 050		26
28	3 600	3 200	2 800	2 700	2 350	2 350	1 900	1 900		28
30	3 550	3 050	2 650	2 500	2 200	2 000	1 700	1 550	1 550	30
32	3 400	2 900	2 550	2 350	2 050	1 900	1 550	1 400	1 250	32
34	3 150	2 750	2 450	2 200	1 950	1 750	1 400	1 250	1 150	34
36	2 800	2 650	2 400	2 050	1 800	1 650	1 300	1 150	1 050	36
38	2 500	2 550	2 300	1 950	1 700	1 550	1 150	1 000	950	38
40	2 250	2 350	2 200	1 800	1 600	1 500	1 050	900	800	40
42	2 000	2 100	2 150	1 600	1 500	1 400	950	800	750	42
44	1 650	1 850	2 000	1 400	1 450	1 300	850	700	650	44
46	1 350	1 650	1 750	1 200	1 300	1 250	750	650	550	46
48	1 100	1 350	1 550	1 000	1 100	1 200	650	550		48
50	850	1 050	1 250	800	950	1 050	500			50
52	600	800	1 000	550	750	850				52
54		600	750		550	700				54
56			500			500				56

19 505 kg Counterweight - Fully Extended Outriggers - 360° Rotation
(All Capacities Are Listed In kilograms)

49.38 m Main Boom Length

Radius (m)	22.3 m Hydraulic Offset fly			27.7 m Hydraulic Offset fly			33.2 m Hydraulic Offset fly			Radius (m)
	2° - 15°	15° - 30°	30° - 45°	2° - 15°	15° - 30°	30° - 45°	2° - 15°	15° - 30°	30° - 45°	
18	3 750			2 850						18
20	3 750	3 750		2 850			2 200			20
22	3 750	3 750		2 850			2 200			22
24	3 750	3 400	3 400	2 850	2 850		2 200	2 200		24
26	3 700	3 350	3 350	2 850	2 850		2 050	2 050		26
28	3 600	3 200	2 800	2 700	2 350	2 350	1 900	1 900		28
30	3 550	3 050	2 650	2 500	2 200	2 000	1 700	1 550	1 550	30
32	3 400	2 900	2 550	2 350	2 050	1 900	1 550	1 400	1 250	32
34	3 150	2 750	2 450	2 200	1 950	1 750	1 400	1 250	1 150	34
36	2 800	2 650	2 400	2 050	1 800	1 650	1 300	1 150	1 050	36
38	2 500	2 550	2 300	1 950	1 700	1 550	1 150	1 000	950	38
40	2 250	2 350	2 200	1 800	1 600	1 500	1 050	900	800	40
42	2 000	2 100	2 150	1 600	1 500	1 400	950	800	750	42
44	1 750	1 850	2 000	1 400	1 450	1 300	850	700	650	44
46	1 550	1 650	1 750	1 200	1 300	1 250	750	650	550	46
48	1 350	1 450	1 550	1 000	1 100	1 200	650	550		48
50	1 150	1 250	1 350	850	950	1 050	500			50
52	1 000	1 100	1 150	650	750	850				52
54	850	900	1 000	500	600	700				54
56	700	750	800			500				56
58	550	600	650			500				58
60			500							60
62			500							62

This information is not for crane operation. Operator must refer to the in-cab information for crane operation. Rated lifting capacities shown on fully extended outriggers do not exceed 85% of the tipping loads and on tires do not exceed 75% of the tipping loads.

Metric On Tires Lift Capacity Charts – 85% – Standard

11 794 kg Counterweight - On Tires - Stationary - Boom Centered Over Rear Between Tire Tracks (All Capacities Are Listed In kilograms)								
Radius (m)	Boom Length (m)							Radius (m)
	12.61	16.8	21.3	25.9	30.5	35.1	39.6	
3	41 700							3
3.5	33 650							3.5
4	30 550							4
4.5	27 950	23 100						4.5
5	25 700	23 100						5
6	22 050	23 100	14 900					6
7	19 100	20 550	14 900					7
8	15 550	17 350	14 900	11 850				8
9	12 450	14 250	14 900	11 850	9 750			9
10		11 850	12 900	11 850	9 750	7 850		10
12		8 500	9 500	9 850	9 750	7 850	6 100	12
14		6 300	7 250	7 600	7 800	7 700	6 100	14
16			5 650	5 950	6 200	6 100	6 000	16
18			4 450	4 750	4 950	4 900	4 800	18
20				3 800	4 000	3 950	3 900	20
22				3 050	3 250	3 150	3 100	22
24					2 600	2 550	2 500	24
26					2 100	2 000	1 950	26
28						1 600	1 550	28
30						1 200	1 150	30
32						900	850	32

11 794 kg Counterweight - On Tires - Pick & Carry (Creep) - Boom Centered Over Rear (All Capacities Are Listed In kilograms)								
Radius (m)	Boom Length (m)							Radius (m)
	12.61	16.8	21.3	25.9	30.5	35.1	39.6	
3	40 250							3
3.5	36 700							3.5
4	33 300							4
4.5	30 350	21 950						4.5
5	27 800	21 950						5
6	20 650	21 950	12 150					6
7	15 700	17 500	12 150					7
8	12 300	14 000	12 150	9 750				8
9	9 800	11 450	12 150	9 750	7 950			9
10		9 500	10 500	9 750	7 950	6 450		10
12		6 750	7 750	8 000	7 950	6 450	5 300	12
14		4 850	5 800	6 150	6 350	6 250	5 300	14
16			4 450	4 750	4 950	4 900	4 800	16
18			3 400	3 700	3 900	3 850	3 800	18
20				2 900	3 050	3 000	2 950	20
22				2 250	2 400	2 350	2 300	22
24					1 900	1 800	1 750	24
26					1 450	1 350	1 300	26
28						1 000	900	28

This information is not for crane operation. Operator must refer to the in-cab information for crane operation. Rated lifting capacities shown on fully extended outriggers do not exceed 85% of the tipping loads and on tires do not exceed 75% of the tipping loads.

Link-Belt Cranes Lexington, Kentucky www.linkbelt.com

®Link-Belt is a registered trademark. Copyright 2017 We are constantly improving our products and therefore reserve the right to change designs and specifications.